

ANSI/ASABE 6489-3:2004 JUL2017

Agricultural vehicles — Mechanical connections between towed and towing vehicles — Part 3: Tractor drawbar



**American Society of
Agricultural and Biological Engineers**



**S
T
A
N
D
A
R
D**

ASABE is a professional and technical organization, of members worldwide, who are dedicated to advancement of engineering applicable to agricultural, food, and biological systems. ASABE Standards are consensus documents developed and adopted by the American Society of Agricultural and Biological Engineers to meet standardization needs within the scope of the Society; principally agricultural field equipment, farmstead equipment, structures, soil and water resource management, turf and landscape equipment, forest engineering, food and process engineering, electric power applications, plant and animal environment, and waste management.

NOTE: ASABE Standards, Engineering Practices, and Data are informational and advisory only. Their use by anyone engaged in industry or trade is entirely voluntary. The ASABE assumes no responsibility for results attributable to the application of ASABE Standards, Engineering Practices, and Data. Conformity does not ensure compliance with applicable ordinances, laws and regulations. Prospective users are responsible for protecting themselves against liability for infringement of patents.

ASABE Standards, Engineering Practices, and Data initially approved prior to the society name change in July of 2005 are designated as "ASAE", regardless of the revision approval date. Newly developed Standards, Engineering Practices and Data approved after July of 2005 are designated as "ASABE".

Standards designated as "ANSI" are American National Standards as are all ISO adoptions published by ASABE. Adoption as an American National Standard requires verification by ANSI that the requirements for due process, consensus, and other criteria for approval have been met by ASABE.

Consensus is established when, in the judgment of the ANSI Board of Standards Review, substantial agreement has been reached by directly and materially affected interests. Substantial agreement means much more than a simple majority, but not necessarily unanimity. Consensus requires that all views and objections be considered, and that a concerted effort be made toward their resolution.

CAUTION NOTICE: ASABE and ANSI standards may be revised or withdrawn at any time. Additionally, procedures of ASABE require that action be taken periodically to reaffirm, revise, or withdraw each standard.

Copyright American Society of Agricultural and Biological Engineers. All rights reserved.

ASABE, 2950 Niles Road, St. Joseph, MI 49085-9659, USA, phone 269-429-0300, fax 269-429-3852, hq@asabe.org

Agricultural vehicles — Mechanical connections between towed and towing vehicles — Part 3: Tractor drawbar

These materials are subject to copyright claims of ISO and ASABE. No part of this publication may be reproduced in any form, including an electronic retrieval system, without the prior written permission of ASABE. All requests pertaining to the ANSI/ASABE AD6489-3:2004 JUL2017 Standard should be submitted to ASABE.

ASAE S482 history: Proposed by the Equipment Manufacturers Institute; approved by the ASAE Tractor Committee; approved by the Power and Machinery Division Standards Committee; adopted by ASAE March 1994; reaffirmed and revised editorially December 1998; revised editorially March 1999; reaffirmed February 2004; replaced by the adoption with deviations of ISO 6489-3:2004 June 2009; approved by ANSI June 2009; revised July 2014; revision approved by ANSI August 2014, revision approved by ASABE and ANSI July 2017.

Keywords: Clearance zone, Dimensions, Drawbar, Location, Mechanical connections, Power take-off, Safety chain, Tractor

0 Foreword

0.1 ANSI/ASABE AD6489-3:2004, Agricultural vehicles — Mechanical connections between towed and towing vehicles — Part 3: Tractor drawbar, is an adoption with deviations of the identically titled ISO standard ISO 6489-3:2004, Agricultural vehicles — Mechanical connections between towed and towing vehicles — Part 3: Tractor drawbar. Deviations noted in the following sections pertain to those provisions where harmonization could not be achieved between ASABE and the International Standard.

Deviations from the subsequently printed international standard are noted with underscore (addition) or strikethrough (deletions) text. Deviations from the international standard figures and equations are clearly marked.

0.2 This part of ISO 6489 specifies the dimensional requirements and location for Category 0, 1, 2, 3, 4, and 5 drawbars mounted on the rear of agricultural tractors. The following additions apply:

- 0.2.1** Safety chain requirements as outlined in ANSI/ASAE S338.
- 0.2.2** Requirements for clearance between the drawbar and PTO drive shafts.
- 0.2.3** Requirements for the drawbar positions to use with Type 1 and Type 4 PTOs.
- 0.2.4** Requirements for clearance to tires or tracks.
- 0.2.5** Details for an auxiliary hole for drawbar design without clevis.
- 0.2.6** Drawbar loading requirements and recommendations for implement drawbar loads.
- 0.2.7** Maximum drawbar pin diameters.

0.3 Four normative references are listed in ISO 6489-3:2004. The responsible ASABE committee has reviewed these references and approved the following deviation(s):

0.3.1 Replace ISO 500-1, Agricultural tractors — Rear-mounted power take-off types 1, 2 and 3 — Part 1: General specifications, safety requirements, dimensions for master shield and clearance zone, with ANSI/ASABE

AD500-1:2014, Agricultural tractors — Rear-mounted power take-off types 1, 2, 3 and 4 — Part 1: General specifications, safety requirements, dimensions for master shield and clearance zone. Any reference to ISO 500-1 in the printed portion of the ISO text shall be replaced by ANSI/ASABE AD500-1:2014.

0.3.2 Replace ISO 5673-2, Agricultural tractors and machinery — Power take-off drive shafts and power-input connection — Part 2: Specification for use of PTO drive shafts, and position and clearance of PTO drive line and PIC for different attachments, with ANSI/ASABE AD5673-2:2005 SEP2014, Agricultural tractors and machinery — Power take-off drive shafts and power-input connection — Part 2: Specification for use of PTO drive shafts, and position and clearance of PTO drive line and PIC for different attachments. Any reference to ISO 5673-2 in the printed portion of the ISO text shall be replaced by ANSI/ASABE AD5673-2:2005.

0.3.3 Add the following normative reference: ANSI/ASABE S625, Drawbar Pin Dimensions and Requirements for Towed Equipment.

0.3.4 Add the following normative reference: ANSI/ASAE S338, Field Equipment for Agriculture — Safety Chain for Towed Equipment

0.4 This standard has been approved as an American National standard by ANSI (American National Standard Institute). The original content of ISO 6489-3:2004 was based on ASAE S482, Drawbars — Agricultural Wheel Tractors

0.5 This standard deviates from ISO 6489-3:2004 as follows:

0.5.1 See section 0.2 for scope deviations.

0.5.2 See section 0.3 for normative reference deviations.

0.5.3 Add section 4.0. Safety chain; Safety chain requirements and compatibility with ANSI/ASAE S338 shall be met.

0.5.4 Add to section 4.1 Drawbar clevis:

The vertical location of the drawbar below the PTO centerline shall consider the drawbar pin, pin retention device, and clevis for the driveline clearance plane, dimension *V* (see Figure 3). In locating the drawbar vertically relative to the PTO shaft, designers should consider ANSI/ASABE AD5673-2 for placement of the PTO drive shaft. If clearance between the clevis and the PTO drive shaft cannot be maintained then the clevis may be removed to maintain the *V* dimension for PTO operation. If so, the operator's manual should state that the drawbar with clevis installed is not compatible for use with PTO driven implements.

0.5.5 In Table 2 – Drawbar location — Values of the dimension *S* and *U*: Remove footnote b.

0.5.6 Make the following changes to Table 3, Drawbar position — Values of the dimension *T*.

0.5.6.1 Place PTO type 1 and PTO type 2 on separate lines of the table. All values remain the same except for PTO type 1, regular drawbar position is 350 and extended drawbar position 500.

0.5.6.2 Change PTO type 3 to 3 and 4. Values remain the same.

0.5.6.3 Replace footnote b with the following: Short drawbar position shall not be used in PTO operation. Footnote location in table moved from PTO values to header "Short drawbar position."

0.5.7 Add after Table 3: Recommendation for longitudinal distance (Dimension *L*) of 25 mm minimum for all drawbar categories from the hitch pin hole to the tire OD for wheeled tractors as shown in Figure 0.1, or for tracked tractors, from the hitch pin hole to the rear most vertical tangent line with the tracks at their rearmost pivoted position, as shown in Figure 0.2.

Dimension *L* in Figure 0.1 and Figure 0.2 applies to the regular drawbar position for PTO usage.

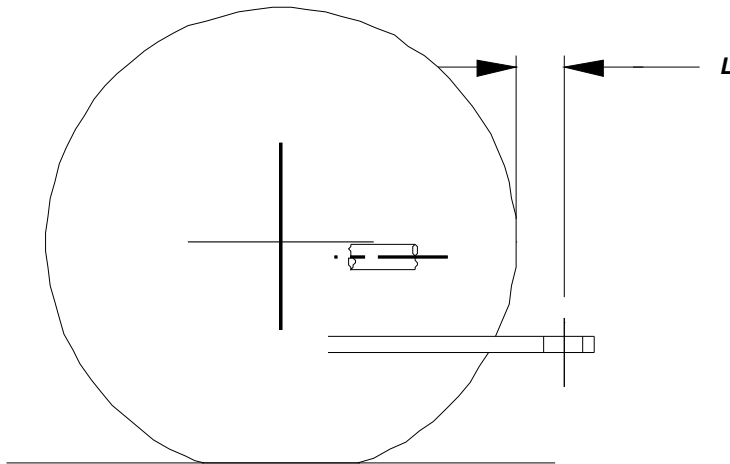

Figure 0.1 – Location of dimension *L*

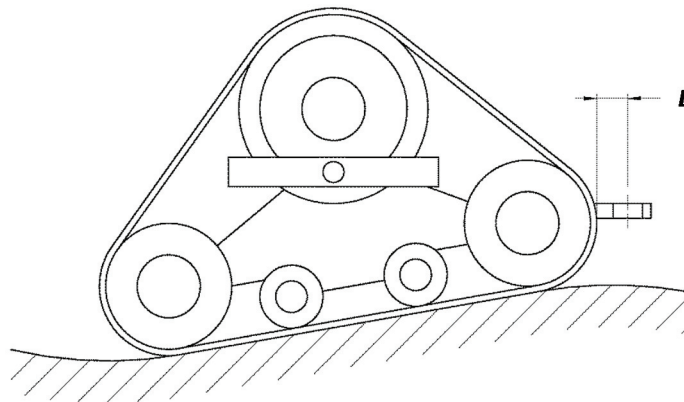

Figure 0.2 – Location of dimension *L*

Dimension *L* does not apply to shorter drawbar positions where PTOs are not used.

Dimension *L* applies with drawbar centered laterally.

Use maximum grown diameter for largest R1/R1W tires that will be specified for tractor.

0.5.8 In Table 4 – Tractor drawbar and clevis — Dimension values: replace values in Pin diameter C1 line with: Refer to ANSI/ASABE S625 — Drawbar Pin Dimensions and Requirements for Towed Equipment, for complete drawbar pin dimensions.

0.5.9 Add after Table 4: The auxiliary hole is used for other hitching applications which require the clevis to be removed from the tractor drawbar for installation of special attachments or for connecting to implements that have a clevis.

Table 0.4 – Tractor drawbar auxiliary hole dimensions

Dimension, mm	Drawbar Category					
	0	1	2	3	4	5
Auxiliary hole diameter, <i>D</i>	NA	21 +0.8	21 +0.8	23.5 +0.8/ -3.3	NA	NA
Distance, <i>E</i>	NA	102 ±0.8	102 ±0.8	102 ±0.8	NA	NA