

Australian/New Zealand Standard™

**Low-voltage switchgear and
controlgear—Controller-device
interfaces (CDIs)**

Part 5: Smart distributed system (SDS)



Standards Australia



STANDARDS
NEW ZEALAND
Pūrongo Aotearoa

AS/NZS 62026.5:2001

This Joint Australian/New Zealand Standard was prepared by Joint Technical Committee EL-006, Industrial Switchgear and Controlgear. It was approved on behalf of the Council of Standards Australia on 21 March 2001 and on behalf of the Council of Standards New Zealand on 4 May 2001. It was published on 5 June 2001.

The following interests are represented on Committee EL-006:

Australasian Railway Association
Australian Chamber of Commerce and Industry
Australian Electrical and Electronic Manufacturers Association
Bureau of Steel Manufacturers of Australia
Electrical Contractors Association of New Zealand
Electricity Supply Association of Australia
Independent Electrical Switchboard Manufacturers Association
Institution of Engineers Australia
Ministry of Economic Development New Zealand
National Electrical and Communications Association
Testing Interests (Australia)
WorkCover N. S. W.

Keeping Standards up-to-date

Standards are living documents which reflect progress in science, technology and systems. To maintain their currency, all Standards are periodically reviewed, and new editions are published. Between editions, amendments may be issued. Standards may also be withdrawn. It is important that readers assure themselves they are using a current Standard, which should include any amendments which may have been published since the Standard was purchased.

Detailed information about joint Australian/New Zealand Standards can be found by visiting the Standards Australia web site at www.standards.com.au or Standards New Zealand web site at www.standards.co.nz and looking up the relevant Standard in the on-line catalogue.

Alternatively, both organizations publish an annual printed Catalogue with full details of all current Standards. For more frequent listings or notification of revisions, amendments and withdrawals, Standards Australia and Standards New Zealand offer a number of update options. For information about these services, users should contact their respective national Standards organization.

We also welcome suggestions for improvement in our Standards, and especially encourage readers to notify us immediately of any apparent inaccuracies or ambiguities. Please address your comments to the Chief Executive of either Standards Australia International or Standards New Zealand at the address shown on the back cover.

Australian/New Zealand Standard™

Low-voltage switchgear and controlgear—Controller-device interfaces (CDIs)

Part 5: Smart distributed system (SDS)

First published as AS/NZS 62026.5:2001.

COPYRIGHT

© Standards Australia/Standards New Zealand

All rights are reserved. No part of this work may be reproduced or copied in any form or by any means, electronic or mechanical, including photocopying, without the written permission of the publisher.

Jointly published by Standards Australia International Ltd, GPO Box 5420, Sydney, NSW 2001 and Standards New Zealand, Private Bag 2439, Wellington 6020

ISBN 0 7337 3866 4

PREFACE

This Standard was prepared by the Joint Standards Australia/Standards New Zealand Committee EL-006, Industrial Switchgear and Controlgear.

The objective of this Standard is to specify requirements for interfaces between control devices and switching elements, normal service conditions for devices, constructional and performance requirements and tests to verify conformance to requirements.

This Standard is Part 5 of a series which, when complete, will consist of the following:

AS/NZS

62026 Low-voltage switchgear and controlgear—Controller-device interfaces (CDIs)

62026.1 Part 1: General rules

62026.2 Part 2: Actuator sensor interface (AS-i)

62026.3 Part 3: DeviceNet

62026.5 Part 5: Smart distributed system (SDS) (This Standard)

62026.6 Part 6: Seriplex (Serial multiplexed control Bus)

This Standard is identical with and has been reproduced from IEC 62026-5:2000, *Low-voltage switchgear and controlgear—Controller-device interfaces (CDIs)—Part 5: Smart distributed system (SDS)*.

This Standard covers controller-device interfaces for control systems, factory automation and material handling including devices such as limit switches, proximity sensors, electro-pneumatic valves, relays, motor-starters, operator interface panels, analogue inputs, analogue outputs and controllers.

The provisions of the general rules in AS/NZS 62026.1 are applicable to this Joint Australian/New Zealand Standard, where specifically called for. General rules clauses and subclauses thus applicable, as well as tables, figures and annexes, are identified by reference to Part 1 of the IEC Standard from which this Standard is reproduced, for example subclause 7.2.4.1 of IEC 62026-1.

The smart distributed system (SDS) is intended for use in, but is not limited to, controller-device interfaces for control systems, factory automation and material handling. These applications may include devices such as limit switches, proximity sensors, electro-pneumatic valves, relays, motor-starters, operator interface panels, analogue inputs, analogue outputs and controllers.

SDS provides for the connection of intelligent devices such as sensors, actuators and other components to one or more controllers. SDS functionality may be integrated directly into the devices or be in modules allowing the connection of conventional components to the network.

SDS consists of one or more controllers connected to up to 126 logical devices. In addition to the process data, SDS allows for the transmission of parameters and diagnostic data. The data exchange may be either event-driven or cyclical.

Topology is typically a single trunk with short branches using a cable comprising two shielded, twisted pairs with a common earth wire within a single jacket.

Data can be transmitted at rates of 125 kbit/s, 250 kbit/s, 500 kbit/s and 1 Mbit/s with maximum system trunk lengths of 457 m, 182 m, 91 m and 22 m respectively.

Figure 1 shows an example of an SDS controller-device interface.

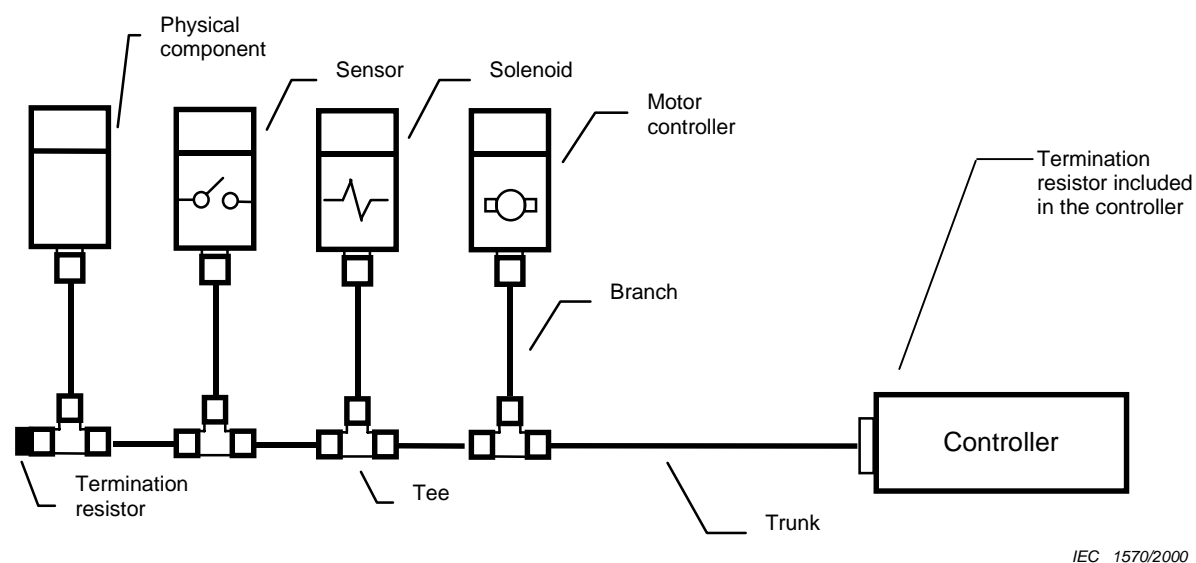

Figure 1 – Example of an SDS controller-device interface scope

A reference to an International Standard identified in the Normative References Clause by strikethrough (~~example~~) is replaced by a reference to the Australian or Australian/New Zealand Standard(s) listed immediately thereafter and identified by shading (**example**). Where the struck-through referenced document and the referenced Australian or Australian/New Zealand Standard are identical, this is indicated in parenthesis after the title of the latter.

As this Standard is reproduced from an International Standard, the following applies:

- (a) Its number does not appear on each page of text and its identity is shown only on the cover and title page.
- (b) In the source text 'this standard' should read 'this Australian/New Zealand Standard'.
- (c) A full point should be substituted for a comma when referring to a decimal marker.

CONTENTS

	<i>Page</i>
1 Scope.....	1
2 Normative references	1
3 Definitions, abbreviations and symbols.....	3
3.1 Definitions	3
3.2 Abbreviations	4
3.3 Symbols	5
4 Classification.....	5
5 Characteristics	5
5.1 SDS overview.....	5
5.2 SDS application layer services	8
5.3 SDS application layer protocol.....	13
5.4 SDS APDUs embedded in CAN frames	24
5.5 Examples of short form APDUs	26
5.6 Examples of long form APDUs.....	26
6 Product information	26
7 Normal service, transport and mounting conditions.....	27
7.1 Normal service conditions	27
7.2 Conditions during transport and storage	27
7.3 Mounting	27
8 Constructional and performance requirements.....	27
8.1 Physical layer interface (PLI).....	27
8.2 SDS controller-device interface	30
8.3 Electromagnetic compatibility (EMC)	32
9 Tests.....	34
9.1 General requirements.....	34
9.2 Product model.....	34
9.3 Object model test	35
9.4 Physical layer test.....	37
9.5 Application layer test.....	41
9.6 System test	46
9.7 Electromagnetic compatibility tests.....	47
Figure 1 – Example of an SDS controller-device interface.....	iii
Figure 2 – SDS protocol architecture compared with the OSI reference model.....	5
Figure 3 – Logical representation of SDS.....	6
Figure 4 – Graphical representation of component model.....	6
Figure 5 – SDS example of models in hierarchical form	7
Figure 6 – Representation of the service primitives without fragmentation.....	8
Figure 7 – Representation of the service primitives with fragmentation	9
Figure 8 – CAN frame format	14
Figure 9 – Short form APDU structure.....	15
Figure 10 – Long form APDU format	17

	<i>Page</i>
Figure 11 – Error response APDU format.....	19
Figure 12 – Unsigned 8 integer.....	21
Figure 13 – Unsigned 16 integer.....	21
Figure 14 – Unsigned 32 integer.....	22
Figure 15 – Signed 8 integer.....	22
Figure 16 – Signed 16 integer.....	22
Figure 17 – Signed 32 integer.....	23
Figure 18 – Real numbers.....	23
Figure 19 – SDS short form APDU.....	24
Figure 20 – SDS long form APDU.....	25
Figure 21 – SDS long form fragmented APDU.....	25
Figure 22 – COS OFF APDU from logical address 25.....	26
Figure 23 – COS OFF ACK APDU to logical address 25.....	26
Figure 24 – Read request to logical address 16, embedded object 0, variable 8.....	26
Figure 25 – Read response from logical address 16, embedded object 0, variable 8.....	26
Figure 26 – Network grounding.....	32
Figure 27 – Device conformance test set-up.....	35
Figure 28 – Input threshold test circuit.....	38
Figure 29 – Output level test circuit.....	39
Figure 30 – Current loss test set-up.....	40
Figure 31 – System test set-up.....	46
Figure 32 – Test set-up.....	48
Table 1 – SDS application layer services.....	8
Table 2 – Parameters defined for read service.....	9
Table 3 – Parameters defined for write service.....	10
Table 4 – Parameters defined for event service.....	11
Table 5 – Parameters defined for action service.....	11
Table 6 – Parameters defined for change of state ON service.....	12
Table 7 – Parameters defined for change of state OFF service.....	12
Table 8 – Parameters defined for write state ON service.....	13
Table 9 – Parameters defined for write state OFF service.....	13
Table 10 – Short form service type values.....	16
Table 11 – Long form service types.....	18
Table 12 – Data length codes for long form APDUs.....	18
Table 13 – Request/response sub-field for long form APDUs.....	19
Table 14 – Fragmentation indicator (FI) sub-field.....	19
Table 15 – Embedded object identifier field.....	20
Table 16 – APDU error codes.....	20
Table 17 – Discrete transmitter specifications.....	28
Table 18 – Discrete receiver specifications.....	29

	<i>Page</i>
Table 19 – Integrated transmitter specifications	29
Table 20 – Integrated receiver specifications	29
Table 21 – Optocoupled transmitter specifications	29
Table 22 – Optocoupled receiver specifications	30
Table 23 – General requirements for SDS cable	31
Table 24 – SDS connector specifications	31
Table 25 – Maximum trunk length for various data rates	31
Table 26 – SDS standard cable wire termination and colour code	32
Table 27 – Performance criteria	33
Table 28 – Data values	41
Table 29 – Maximum branch lengths	47
Table 30 – Trunk lengths for emission tests	49

STANDARDS AUSTRALIA/STANDARDS NEW ZEALAND

Australian/New Zealand Standard**Low-voltage switchgear and controlgear—Controller-device interfaces
(CDIs)****Part 5: Smart distributed system (SDS)**

Any IEC table, figure or passage of text that is struck-through is not part of this Standard. Any Australian/New Zealand table, figure or passage of text that is added (and identified by shading) is part of this Standard.

1 Scope

This International Standard specifies an interface system between a single or multiple controlling device and control circuit devices or switching elements as defined in IEC 60947-5-2, connected by a shielded, twisted four-wire cable carrying data and power, and establishes a system for the interchangeability of components with such interfaces.

The object of this standard is to define, for smart distributed systems (SDS) interfaces:

- requirements for interfaces between control devices and switching elements;
- normal service conditions for devices;
- constructional and performance requirements;
- tests to verify conformance to requirements.

2 Normative references

The following normative documents contain provisions which, through reference in this text, constitute provisions of this International Standard. For dated references, subsequent amendments to, or revisions of, any of these publications do not apply. However, parties to agreements based on this International Standard are encouraged to investigate the possibility of applying the most recent editions of the normative documents indicated below. For undated references, the latest edition of the normative document referred to applies. Members of IEC and ISO maintain registers of currently valid International Standards.

References to International Standards that are struck through in this Clause are replaced by references to equivalent Australian or Australian/New Zealand Standards that are listed immediately thereafter and identified by shading. Any Australian or Australian/New Zealand Standard that is identical to the International Standard it replaces is appropriately identified.

CISPR 11:1997, *Industrial, scientific and medical (ISM) radio-frequency equipment – Electromagnetic disturbance characteristics – Limits and methods of measurement*

~~IEC 60947-1:1999, *Low-voltage switchgear and controlgear – Part 1: General rules*~~

AS/NZS 3947.1, *Low-voltage switchgear and controlgear, Part 1: General rules*