

317
SUPERSEDED BY AS 2317 - 1984
under revision see DR 83030 of Feb 1983

Dep.

AS 2317-1979
UDC 621.885.9: 621.86.061.1

Australian Standard 2317-1979

EYEBOLTS



STANDARDS ASSOCIATION OF AUSTRALIA
Incorporated by Royal Charter



THE FOLLOWING SCIENTIFIC, INDUSTRIAL AND GOVERNMENTAL ORGANIZATIONS and departments were officially represented on the committee entrusted with the preparation of this standard:

Australasian Steamship Owners Federation
Australian Chamber of Commerce
Bureau of Steel Manufacturers of Australia
Confederation of Australian Industry
Department of Defence
Department of Industrial Relations and Technology, N.S.W.
Department of Labour and Industry, South Australia
Department of Labour and Industry, Tasmania
Department of Labour and Industry, Victoria
Department of Labour Relations, Queensland
Department of Mines and Energy, Northern Territory
Department of Productivity
Department of the Capital Territory
Department of Transport
Electricity Supply Association of Australia
Master Builders Association of N.S.W.
Metal Trades Industry Association of Australia
Railways of Australia Committee

This standard, prepared by Committee ME/25, Lifting Tackle, was approved on behalf of the Council of the Standards Association of Australia on 10 September 1979, and was published on 31 December 1979.

To keep abreast of progress in industry, Australian standards are subject to continuous review and are kept up-to-date by the issue of amendments or revised editions as necessary. It is important therefore that standards users ensure that their standards are up-to-date. Full details of all SAA publications will be found in the Annual List of Australian Standards; these details are supplemented by monthly listings in the SAA Monthly Information Sheet. Information on the Annual List and the SAA Monthly Information Sheet may be obtained from any sales office of the Association, where details are also available of the current status of individual standards.

This standard was issued in draft form for public review as DR 76091.

AUSTRALIAN STANDARD

EYEBOLTS

AS 2317—1979

First published (as AS B284)	1969
Revised and issued as AS 2317	1979

**PUBLISHED BY THE STANDARDS ASSOCIATION OF AUSTRALIA
STANDARDS HOUSE, 80 ARTHUR ST, NORTH SYDNEY, N.S.W.**

ISBN 0 7262 1797 2



PREFACE

This standard was prepared by the Association's Committee on Lifting Tackle as a metrication and revision of AS B284—1969, Eyebolts for Lifting Purposes, which it accordingly supersedes.

It is one of a series of standards for components of lifting systems and staying and tensioning systems. Other standards dealing with lifting systems and staying and tensioning systems are as follows:

- AS 1138 Thimbles for Use with Wire Rope or Fibre (Natural or Synthetic) Rope
- AS 1353 Synthetic-webbing Flat Slings
- AS 1380 Fibre-rope Slings (of Natural or Synthetic Rope)
- AS 1438 Wire-coil Flat Slings
- AS 1656 Steel Wire Ropes (Other Than for Mining Purposes)
- AS 1666 Wire Rope Slings
- AS 2076 Wire Rope Grips
- AS 2089 Sheave Blocks (Including Ships' Cargo Blocks) of Maximum Lift 60 t
- AS 2318 Swivels
- AS 2319 Rigging Screws and Turnbuckles
- AS 2321 Short-link Chain for Lifting Purposes—Non-calibrated
- *AS B278 Shackles for Lifting Purposes
- *AS B283 Bordeaux Connections
- *AS B291 Lifting Rings and Links
- *AS MB1 SAA Steel Wire Rope Manual

Australian standards are being prepared for other components which are used with lifting systems and with staying and tensioning systems. They are: chain slings, hooks, and wedge-type sockets for wire rope.

This standard is prepared as a 'performance' rather than a 'dimensional' standard. It covers only steel eyebolts with collars used for general lifting purposes, and staying and tensioning purposes, therefore the title has been aligned accordingly. Eyebolts with links have been excluded because the committee considered it preferable that lifting slings be attached to eyebolts by means of shackles. The diameter of the eye is larger than previously specified in AS B284, and is in accordance with the recommendations of ISO†, but the thread length of 1.5 times the nominal outside diameter of the thread has been maintained to ensure sufficient thread length in tapped holes in low tensile strength materials such as grey cast iron.

Eyebolts smaller than 12 mm nominal size are excluded from this standard because of the danger of the creation of high torsional stress should the eyebolt be screwed up too tightly during fitting. Eyebolts smaller than 12 mm nominal size are therefore not recommended for use for general lifting purposes and staying and tensioning purposes.

The opportunity has been taken to align material designations with those adopted by the ISO/TC 111, Round Steel Link Chains, Chain Wheels, Lifting Hooks and Accessories. ISO has made provision for the following tabulated grades, and those adopted by

the committee for lifting tackle equipment standards in Australia are designated as the preferred grades:

Preferred grade	Non-preferred grade	Old grade designation
L	—	Lower tensile steel
—	M	Higher tensile steel
P	—	Higher tensile steel
—	S	Alloy steel
T	—	Alloy steel
—	V	—

Not all of these preferred grades are designated for each lifting tackle product. Some are restricted to recommendation of one grade only, e.g. AS, Bordeaux Connections, designates the preferred grade P and this standard designates the non-preferred grade M. Owing to local conditions and requirements, the Australian designated preferred grades for the various products differ from those grades nominated by ISO for comparable products. To date there is no ISO standard for eyebolts but it is in the course of preparation.

Guidance regarding the safe working loads of eyebolts used in pairs is given in Appendix A, and Appendix C outlines details on the fitting of eyebolts used in pairs, and suggests precautions to be taken against the fitting of eyebolts with metric threads into tapped holes having a BSW or UNC thread, or *vice versa*. It is recommended that the body be marked and possibly a plug inserted in the threaded hole when an eyebolt is removed.

Information to be supplied with enquiry and order to ensure that the manufacturer or supplier quotes on and supplies the correct eyebolt to fulfil the requirements of the purchaser is provided in Appendix B. Appendix D covers eyebolt finishes other than self-colour.

This standard may require reference to the following Australian standards:

- AS 1057 Glossary of Terms Used in Quality Control
- AS 1275 Metric Screw Threads for Fasteners (Based on ISO Recommendations)
- AS 1391 Methods for Tensile Testing of Metals
- AS 1418 SAA Crane Code
- AS 1442 Carbon Steels and Carbon-manganese Steels—Hot-rolled Bars and Semi-finished Products
- AS 1444 Wrought Alloy Steels of the AISI-SAE H and Standard Steels Types
- AS 1627 Code of Practice for Preparation and Pretreatment of Metal Surfaces Prior to Protective Coating Part 6—Phosphate Treatment of Iron and Steel Surfaces

*In course of metrication and revision.

†International Organization for Standardization.

AS 1650	Galvanized Coatings on Ferrous Articles	AS 1789	Electroplated Coatings of Zinc on Iron and Steel
AS 1654	Limits and Fits for Engineering	AS 1790	Electroplated Coatings of Cadmium on Iron and Steel
AS 1721	General Purpose Metric Screw Threads	AS B199	Undercuts and Runouts for Screw Threads

CONTENTS

	<i>Page</i>
FOREWORD	4
SPECIFICATION	
1 Scope	5
2 Definitions	5
3 Nominal Size	5
4 Dimensions and Tolerances	5
5 Grade Designation	6
6 Safe Working Load	6
7 Rating	6
8 Material and Heat Treatment	6
9 Manufacture	6
10 Testing....	6
11 Marking	7
12 Test Certificate	7
APPENDICES	
A Safe Working Loads for Eyebolts	8
B Information to be Supplied with Enquiry and Order	10
C Care and Use of Eyebolts	11
D Eyebolt Finishes Other Than Self-colour	12

©Copyright — STANDARDS ASSOCIATION OF AUSTRALIA 1979

Users of standards are reminded that copyright subsists in all SAA publications. No part of this publication may be reproduced, stored in a retrieval system in any form or transmitted by any means without prior permission in writing of the Standards Association of Australia.

STANDARDS ASSOCIATION OF AUSTRALIA

**Australian Standard
for
EYEBOLTS**

FOREWORD

NOTE: Eyebolts welded during manufacture or subsequently are excluded from this standard. Welding is potentially dangerous in eyebolts.

Eyebolts covered by this standard are of quality grade M only. It is one of the quality grades identified by a letter in the series L, M, P, S and T. The range of quality grades extends from 'lower tensile' steel eyebolts (quality grade L) through 'higher tensile' steels (quality grades M and P) to 'alloy' steel eyebolts (quality grades S and T).

This quality grading system applies not only to eyebolts, but also to swivels, rings and/or other accessories, which together form a lifting system or a staying and tensioning system. It relates to the mechanical properties of the finished product and not solely to the strength of the material. For example, an eyebolt of a given quality grade and lifting capacity is capable of being matched by shackles of the same quality grade and lifting capacity to form a lifting system of compatible components. It is, therefore, important that all components of such a lifting system may be quickly and positively identified in service for size, lifting capacity and quality grade. Likewise, the same principle is applicable to the matching of quality grade and load rating of compatible components in a staying and tensioning system.

The materials specified for the eyebolts are the same as those specified in other Australian standards for other components of lifting tackle. Steels to Australian standards have been specified but other approved materials may be used. Heat treatment appropriate to the grade of steel used is also specified.

Eyebolts are used in lifting systems and in staying and tensioning systems. The collar on an eyebolt adds substantially to its load-carrying capacity where the eyebolt is correctly fitted to the item to be lifted, stayed or tensioned.

The safe working load of the eyebolt and that of other components constituting a lifting system is to be compatible with the load inherent in or applied to the system.

The eyebolt load rating and that of other components constituting a guy or other staying or tensioning system is to be compatible with the loading inherent in or applied to the staying or tensioning system.

SPECIFICATION

1 SCOPE. This standard specifies requirements for forged eyebolts for general lifting purposes and staying and tensioning purposes having shank diameters between 12 mm and 100 mm, and eye diameters suitable for use with a shackle. Materials, heat treatment, key dimensions, manufacture, testing, marking and certification are specified.

NOTES:

1. For eyebolts other than self-coloured, see Appendix D.
2. For information that should be supplied with an enquiry or order, see Appendix B.

2 DEFINITIONS. For the purpose of this standard, the following definitions apply.

2.1 Approved and approval—approved by or the approval of the Statutory Authority.

2.2 Finished condition—the condition of an eyebolt after completion of all processing and proof loading.

2.3 Processing—any treatment of the eyebolts subsequent to forging, e.g. heat treatment, but excluding proof loading and temporary protective coating.

2.4 Proof load—the minimum force to which after processing (see Clause 2.3) the eyebolt is subjected as specified in Clause 10.3 and Table 4.

2.5 Self-colour—an eyebolt of self-colour is one with the surface finish arising from the essential manufacturing operations, the surface finish usually being a closely adhering oxide film due to the heat treatment and subsequent handling.

2.6 Shall and should—‘shall’ is taken to be mandatory; ‘should’ is taken to be advisory.

2.7 Statutory Authority—an authority having statutory powers to control the design, manufacture and use of lifting tackle in the State or Territory within the Commonwealth of Australia in which the lifting tackle is to be used.

3 NOMINAL SIZE. The nominal size of the eyebolt shall be the nominal outside diameter of the thread of the screwed shank.

4 DIMENSIONS AND TOLERANCES.

4.1 Dimensions. Eyebolts shall conform to the dimensions specified in Table 1 and Fig. 1.

NOTE: The portion of the shank adjacent to the collar shall be undercut to conform to Clause 9.2.

**TABLE 1
EYEBOLT DIMENSIONS**

millimetres				
1	2	3	4	5
Nominal size and A	B	E	F	H min.
M12	28	28	9.5	23
M16	34	34	12.5	30
M20	40	40	16	38
M24	48	48	19	45
M30	56	56	24	56
M36	67	67	28	66
M42	80	80	34	77
M48	95	95	38	87
M56	112	112	45	101
M64	125	125	50	114
M72 × 6	140	140	58	126
M80 × 6	160	160	63	138
M90 × 6	180	180	71	153
M100 × 6	200	200	80	168

4.2 Tolerances.

4.2.1 Forging tolerances. The dimensions of the unmachined portion of the eyebolt shall be not less than the dimensions given in Table 1. The tolerance on the internal diameter of the eyebolt shall be + 5 percent. The tolerance on the displacement of the axis of the shank in relation to the axis of the eye, in the plane of the eye and at right angles to the plane of the eye, shall be ± 5 percent.

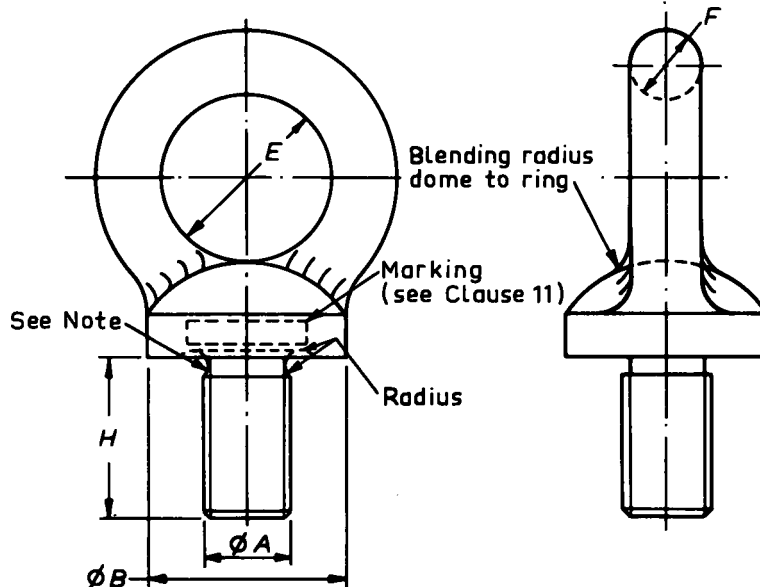

Fig. 1. DIMENSIONS OF EYEBOLTS