

Australian Standard<sup>®</sup>

---

**SAA PACKAGING CODE**

**Part 9.2—METAL CONTAINERS—  
STEEL DRUMS**

---

This Australian Standard was prepared by Committee PK/25, Packaging Code. It was approved on behalf of the Council of Standards Australia on 21 January 1988 and published on 5 April 1988.

---

The following interests are represented on Committee PK/25:

Adhesives and Sealants Manufacturers Association of Australia  
Agricultural and Veterinary Chemicals Association of Australia Ltd  
Ansett Airlines of Australia  
Australian Institute of Packaging  
Australian Timber Producers Council  
Bureau of Steel Manufacturers of Australia  
Canmakers Institute of Australia  
Confederation of Australian Industry  
Cordage Institute of Australia  
Department of Defence  
Glass Packaging Institute of Australia  
Packaging Council of Australia  
Printing and Allied Trades Employers Federation of Australia  
Railways of Australia Committee  
Technical Association of the Australian and New Zealand Pulp and Paper Industry  
(APPITA)  
The Plastics Institute of Australia Inc

---

**Review of Australian Standards.** *To keep abreast of progress in industry, Australian Standards are subject to periodic review and are kept up to date by the issue of amendments or new editions as necessary. It is important therefore that Standards users ensure that they are in possession of the latest edition, and any amendments thereto.*

*Full details of all Australian Standards and related publications will be found in the Standards Australia Catalogue of Publications; this information is supplemented each month by the magazine 'The Australian Standard', which subscribing members receive, and which gives details of new publications, new editions and amendments, and of withdrawn Standards.*

*Suggestions for improvements to Australian Standards, addressed to the head office of Standards Australia, are welcomed. Notification of any inaccuracy or ambiguity found in an Australian Standard should be made without delay in order that the matter may be investigated and appropriate action taken.*

---

*This Standard was issued in draft form for comment as DR 87004.*

Australian Standard®

---

**SAA PACKAGING CODE**

**Part 9.2—METAL CONTAINERS—  
STEEL DRUMS**

---

First published as AS 2400.9.2—1988

PUBLISHED BY STANDARDS AUSTRALIA  
(STANDARDS ASSOCIATION OF AUSTRALIA)  
1 THE CRESCENT, HOMEBUSH, NSW 2140

ISBN 0 7262 4917 3

## PREFACE

This Standard was prepared by the Association's Packaging Code Committee under the direction of the Packaging Standards Board, as a further Standard of the AS 2400 series, *SAA Packaging Code*.

The aim of this Standard is to provide general information on the materials and types of steel drums.

It is intended for operators who are contemplating the use of steel drums for the first time or who wish to be introduced to the technology and economics of this industry. For those readers who wish to delve deeper, it will provide a useful basis for communication with the suppliers.

The *SAA Packaging Code* has been divided into different parts dealing with specific subjects, as follows:

<i>Part</i>	<i>Title</i>
1	<i>Glossary of packaging terms</i>
2	<i>Basic principles of packaging practice</i>
3	<i>Mechanical aids in package handling</i>
4	<i>Protection against spoilage of packages and their contents by microorganisms, insects, mites and rodents</i>
5	<i>Metal protection*</i>
6	<i>Paper and paperboards</i>
7	<i>Timber containers*</i>
8	<i>Textile bags, sacks and wrappings*</i>
9	<i>Metal containers*</i>
	<i>9.1 Metal cans and tubes*</i>
10	<i>Protection against shock and vibration (cushioning)</i>
11	<i>Cordage*</i>
12	<i>Adhesive closing and sealing tapes</i>
13	<i>Tensional strapping</i>
14	<i>Adhesives</i>
15	<i>Glass containers</i>
16	<i>Flexible packaging</i>
17	<i>Packaging in plastics containers</i>
18	<i>Use of desiccants in packaging</i>
19	<i>Packaging for airfreight</i>
20	<i>Handling of goods in freight containers</i>
21	<i>Packaging of dangerous goods</i>
22	<i>Closures</i>
23	<i>Shrink and stretch wrapping</i>

During the preparation of the *SAA Packaging Code*, reference was made to BS 1133, *Packaging Code*, and the assistance obtained from this source is acknowledged.

The following Standards may be of relevance:

AS	
2348	<i>Guide to the determination of optimum dimensions of packages for unit load handling</i>
2583	<i>Complete, filled transport packages —Distribution trials—Information to be recorded</i>
2584	<i>Complete, filled transport packages —General rules for the compilation of performance schedules</i>
	<i>Part 1—General principles (AS 2584.1)</i>
	<i>Part 2—Quantitative data (AS 2584.2)</i>

---

\* Not yet published.

## CONTENTS

	<i>Page</i>
1 SCOPE .....	4
2 APPLICATION .....	4
3 REFERENCED DOCUMENTS .....	4
4 DEFINITIONS .....	4
5 MATERIALS .....	5
6 MANUFACTURE .....	5
7 CLASSIFICATION .....	5
8 CLOSURES .....	5

## © Copyright — STANDARDS AUSTRALIA

Users of Standards are reminded that copyright subsists in all Standards Australia publications and software. Except where the Copyright Act allows and except where provided for below no publications or software produced by Standards Australia may be reproduced, stored in a retrieval system in any form or transmitted by any means without prior permission in writing from Standards Australia. Permission may be conditional on an appropriate royalty payment. Requests for permission and information on commercial software royalties should be directed to the head office of Standards Australia.

Standards Australia will permit up to 10 percent of the technical content pages of a Standard to be copied for use exclusively in-house by purchasers of the Standard without payment of a royalty or advice to Standards Australia.

Standards Australia will also permit the inclusion of its copyright material in computer software programs for no royalty payment provided such programs are used exclusively in-house by the creators of the programs.

Care should be taken to ensure that material used is from the current edition of the Standard and that it is updated whenever the Standard is amended or revised. The number and date of the Standard should therefore be clearly identified.

The use of material in print form or in computer software programs to be used commercially, with or without payment, or in commercial contracts is subject to the payment of a royalty. This policy may be varied by Standards Australia at any time.

STANDARDS ASSOCIATION OF AUSTRALIA

**Australian Standard**  
**SAA PACKAGING CODE**

**PART 9.2: METAL CONTAINERS—STEEL DRUMS**

**1 SCOPE.** This Standard provides guidance on choice of steel drums for packaging of powders, solids, pastes and liquids with 20 L to 205 L capacity. For the purpose of this Standard, the term drum also includes containers commonly called pails.

**2 APPLICATION.** Steel drums are particularly suitable for reuse or for modes of transport where rough handling is likely to occur. Performance requirements are specified in AS 2905. Steel drums may be used for the transport of dangerous goods if approved in accordance with the requirements of the legislation applicable to the chosen mode of transport. Guidelines are given in AS 2400.21. The development of a packaging system incorporating steel drums should be based on principles given in AS 2400.2. Performance of the developed packaging system should be verified by the tests specified in AS 2582.

**3 REFERENCED DOCUMENTS.** The documents below are referred to in this Standard:

- AS  
1365 Tolerances for hot-rolled and cold-rolled unalloyed low carbon steels (coils and cut lengths)  
1517 Tinplate and blackplate  
Part 1: Sheet (AS 1517.1)  
Part 2: Coil (AS 1517.2)

- 1595 Cold-rolled unalloyed low carbon steel sheet and strip  
2400 SAA Packaging Code  
Part 1: Glossary of packaging terms (AS 2400.1)  
Part 2: Basic principles of packaging practice (AS 2400.2)  
Part 17: Packaging in plastic containers (AS 2400.17)  
Part 21: Packaging of dangerous goods (AS 2400.21)  
2582 Complete, filled transport packages — Methods of Test  
Method 1: Identification of parts when testing (AS 2582.1)  
Method 2: Conditioning for testing (AS 2582.2)  
Method 3: Stacking, compression test (AS 2582.3)  
Method 4: Vertical impact test by dropping (AS 2582.4)  
2905 Steel drums

**4 DEFINITIONS.** For the purpose of this Standard the definitions given in AS 2400.1 and AS 2905 apply. Some are represented in Figure 1.

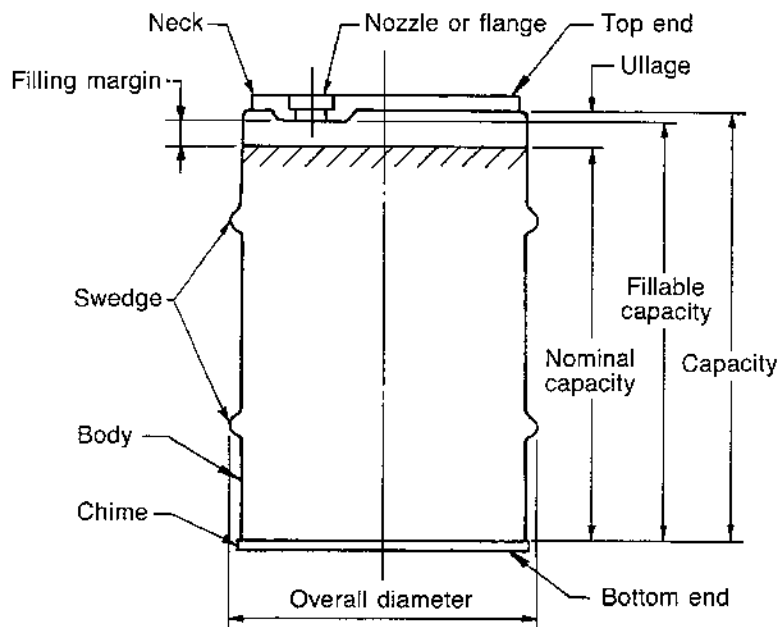

FIGURE 1. DRUM TECHNOLOGY