

AS 1100.201—1992 Mechanical engineering drawing

(In Professional Package 56)

71pp J

Sets out recommendations for mechanical engineering drawing practice. Provides information on surface texture and welding, and the simplified representation of pipelines. Provides details on springs, gears, splines, rolling element bearings, seals and knurling. Appendices provide guidance on the tolerance of machined components and castings.

Committee ME/72. Supersedes AS 1100.201—1984. Draft for Comment DR 90109. Publication date 1992-11-16. ISBN 0 7262 7805 X.

90110

1992 ed.

AS 1100, Part 101—1984
UDC 744:621.7

Amdt 1 - 1987

Australian Standard 1100, Part 101—1984

TECHNICAL DRAWING Part 101—GENERAL PRINCIPLES

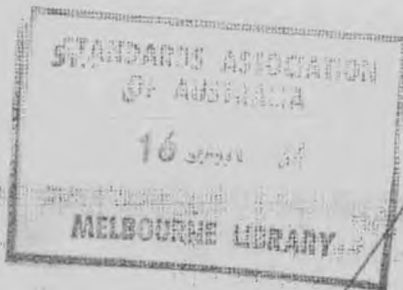

THERE ARE NO STANDARD
DRAWING SYMBOLS -
TO DESIGNATE AN AREA
OFF LIMITS TO THE
USE OF EQUIPMENT.
- FOR BUILDING
PLANS.



STANDARDS ASSOCIATION OF AUSTRALIA
Incorporated by Royal Charter

This Australian standard was prepared by Committee MS/32, Technical Drawing. It was approved on behalf of the Council of the Standards Association of Australia on 30 August 1983 and published on 3 January 1984.

The following interests are represented on Committee MS/32:

Association for Computer Aided Design Limited
Association of Consulting Engineers Australia
Australian Chamber of Commerce
Australian Gas Association
Bureau of Steel Manufacturers of Australia
CSIRO, Division of Applied Physics
Confederation of Australian Industry
Department of Conservation, Forests and Lands
Department of Defence
Department of Defence Support
Department of Housing and Construction
Department of Public Works, New South Wales
Electricity Supply Association of Australia
Institute of Draftsmen Australia
Institute of Industrial Arts
Institution of Engineers Australia
Institution of Production Engineers
Master Builders Federation of Australia
Royal Australian Institute of Architects
Society of Automotive Engineers, Australasia
Telecom Australia
University of Melbourne
University of New South Wales
University of Queensland

Review of Australian Standards. To keep abreast of progress in industry, Australian standards are subject to periodic review and are kept up-to-date by the issue of amendments or new editions as necessary. It is important therefore that standards users ensure that they are in possession of the latest edition, and any amendments thereto.

Full details of all SAA publications will be found in the Annual List of Australian Standards; this information is supplemented each month by SAA's journal 'The Australian Standard', which subscribing members receive, and which gives details of new publications, new editions and amendments, and of withdrawn standards.

Suggestions for improvements to Australian standards, addressed to the head office of the Association, are welcomed. Notification of any inaccuracy or ambiguity found in an Australian standard should be made without delay in order that the matter may be investigated and appropriate action taken.

This standard was issued in draft form for comment as DR 82134.

STANDARDS ASSOCIATION OF AUSTRALIA
Incorporated by Royal Charter

AMENDMENT No 1
to
AS 1100, Part 101—1984
TECHNICAL DRAWING
PART 101—GENERAL PRINCIPLES

CORRECTIONS

SUMMARY: This amendment applies to Preface, Clauses 1.4.7.1, 3.1, 3.2.1, 4.1.4.1, 5.1, 6.4.3.2, and 6.6.1, Figs 1.5, 1.16, 3.2, 3.5, 3.7, 6.7, 6.23, 6.25, 6.36, and 6.44, Tables 3.1 and 6.1, and Paragraphs B3.2, B3.3, and C2.

Published on 6 April 1987.

AMDT
No 1
APR.
1987

Page 2. Preface.

14th paragraph: *delete* existing paragraph and *substitute* :

The requirements of this standard were based on a number of ISO documents. They are as follows:

- | | |
|------------|---|
| ISO 128 | Technical Drawings—General Principles of Presentation |
| ISO/R 129 | Engineering Drawing—Dimensioning |
| ISO 406 | Technical Drawings—Linear and Angular Tolerancing—Indications on Drawings |
| ISO 1101 | Technical Drawings—Geometrical Tolerancing—Tolerancing of Form, Orientation, Location and Run-out—Generalities, Definitions, Symbols, Indications on Drawings |
| ISO 3098/1 | Technical Drawings—Lettering, Part 1—Currently Used Characters. |

AMDT
No 1
APR.
1987

Page 10. Fig. 1.5.

Delete existing figure and *substitute* :

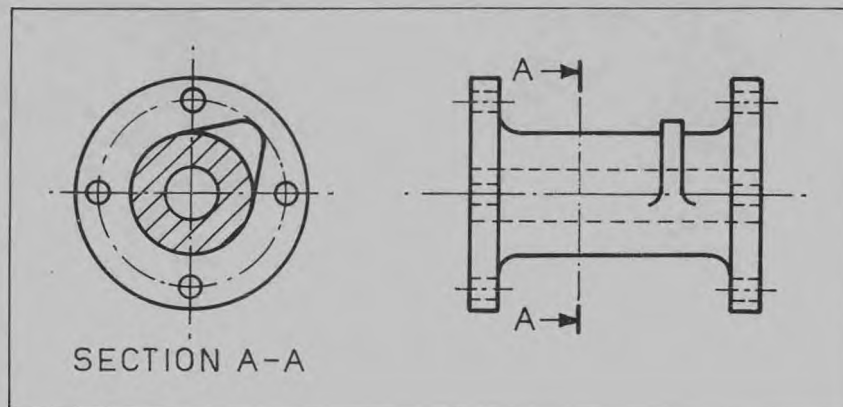

Fig. 1.5. SECTIONAL VIEW

Delete existing figure and substitute :

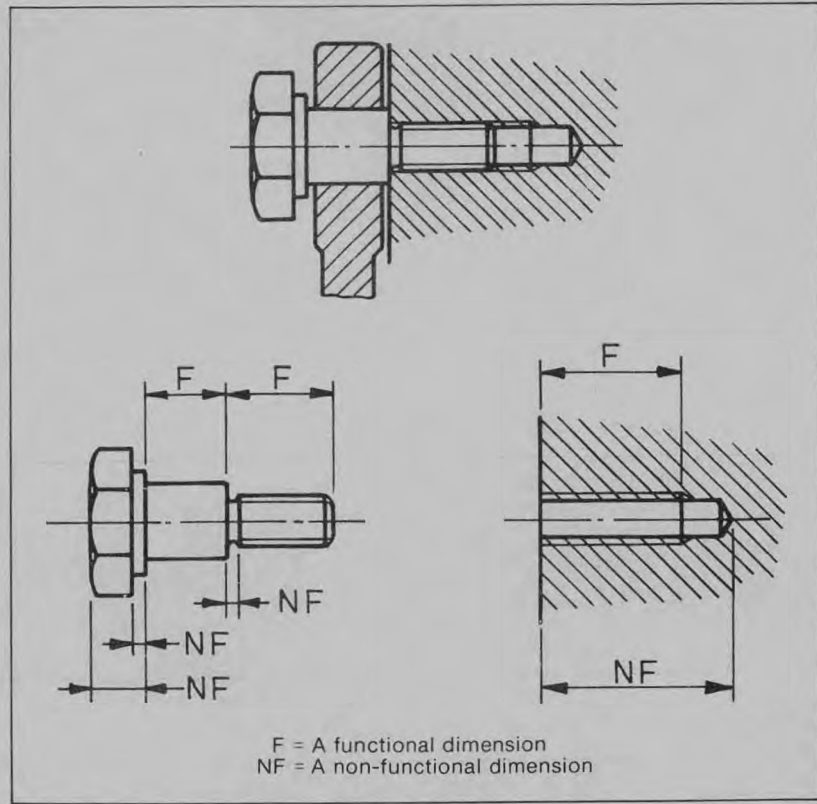

Fig. 1.16. FUNCTIONAL AND NON-FUNCTIONAL DIMENSIONS

Second line: delete 'postional' and substitute 'positional'.

Delete existing clause and substitute :

3.1 TYPES OF LINES. Lines on drawings shall be selected according to their application. Preferred types are shown in Table 3.1 where each type is designated by a letter. Line thicknesses shall be selected from one of the line groups shown in Fig. 3.1. Typical applications are shown in Figs 3.2 to 3.18.

Column 4, heading: delete 'Application' and substitute 'Typical application'.

Column 4, K type lines: delete 'Centroidel' and substitute 'Centroidal'.

Column 5, G type lines: delete '3.2' and substitute '3.3'.

Column 5, G type lines: insert '3.7' in column 5 opposite 'Developed views' in column 4.

AMDT
No 1
APR.
1987

Page 43. Clause 3.2.1.

Fourth line: delete 'printed' and substitute 'reproduced'.

AMDT
No 1
APR.
1987

Page 45. Fig. 3.2.

Delete existing Note at bottom right-hand corner of drawing.

AMDT
No 1
APR.
1987

Page 48. Fig. 3.5.

Delete existing figure and substitute :

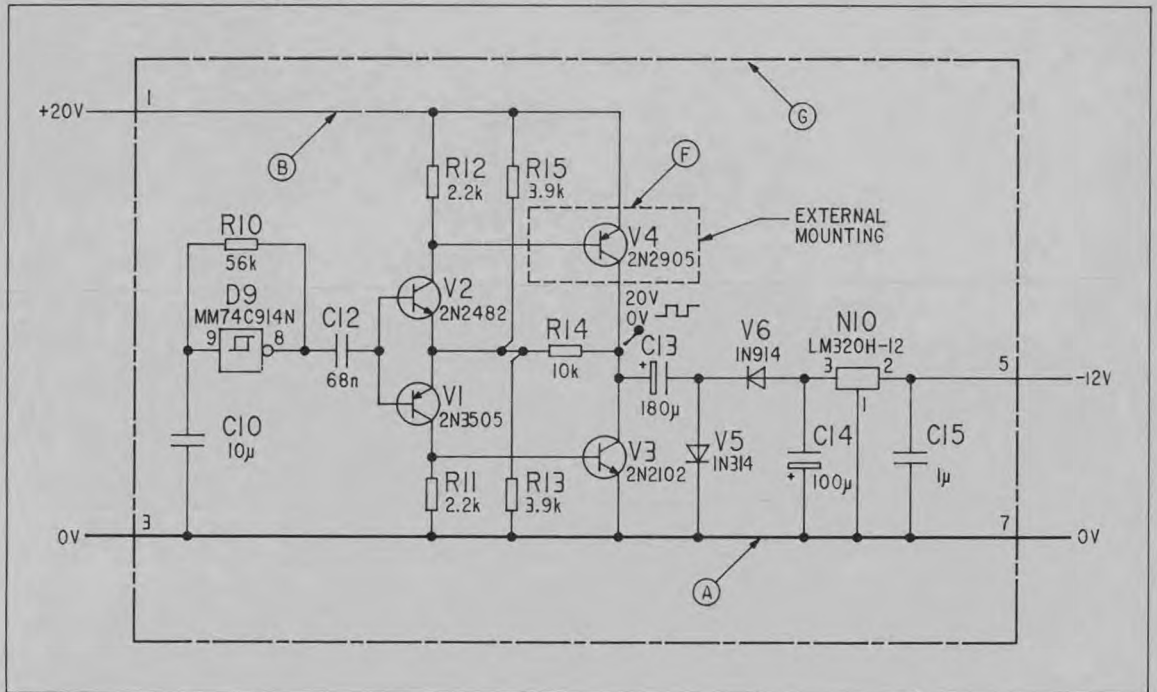

Fig. 3.5. TYPICAL APPLICATION OF TYPES OF LINES—
ELECTROTECHNOLOGY

AMDT
No 1
APR.
1987

Page 49. Fig. 3.7.

Delete existing figure and substitute :

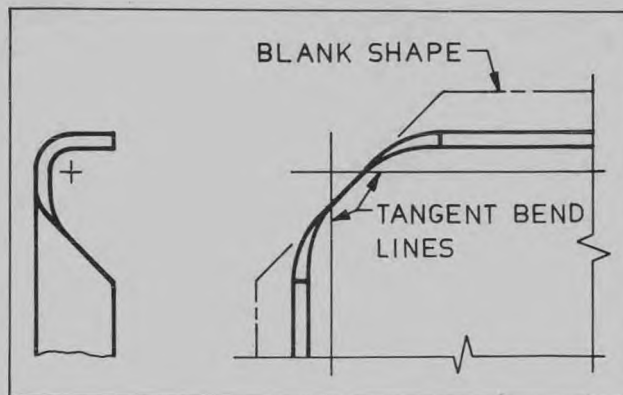

Fig. 3.7. TANGENT BEND LINES

AMDT Page 57. Clause 4.1.4.1.
No 1
APR. Last line: *delete* 'AS 1100' and *substitute* 'AS 1000'.
1987

AMDT Page 62. Clause 5.1.
No 1
APR. First paragraph: *insert* new first sentence as under:
1987
'Drawings should normally be drawn to scale.'

AMDT Page 63. Table 6.1.
No 1
APR. First column: *delete* Converging lines of sight and *substitute* Converging lines of sight
1987

AMDT Page 65. Fig. 6.7.
No 1
APR. *Delete* existing figure (a) and *substitute* :
1987

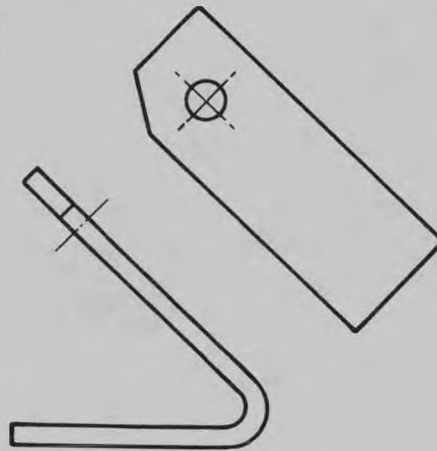

(a) NORMAL (Perpendicular)

AMDT Page 69. Clause 6.4.3.2.
No 1
APR. Fourth paragraph: *delete* existing paragraph and *substitute* :
1987
This is obtained by selecting α and β so that
 $\tan \alpha = \sqrt{1/63}$ and $\tan \beta = \sqrt{7/9}$, i.e. $\alpha = 7^\circ$
approximately, and $\beta = 41.5^\circ$ approximately .

AMDT Page 70. Clause 6.6.1(c).
No 1
APR. *Delete* existing Note and *substitute* :
1987

NOTES:

1. The only lines that can be readily scaled are those lines on the object that actually lie on the plane of projection.
 2. The plane of projection is also known as the picture plane (see Fig. 6.19).
-

AMDT Page 73. Fig. 6.23.
No 1
APR. Delete existing figure and substitute :
1987

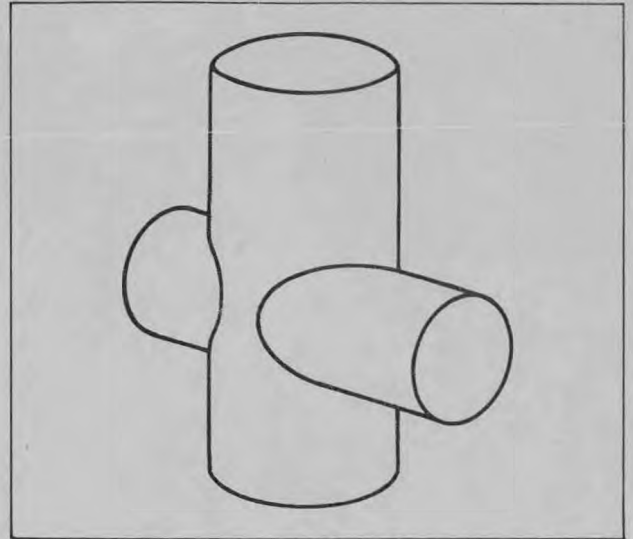
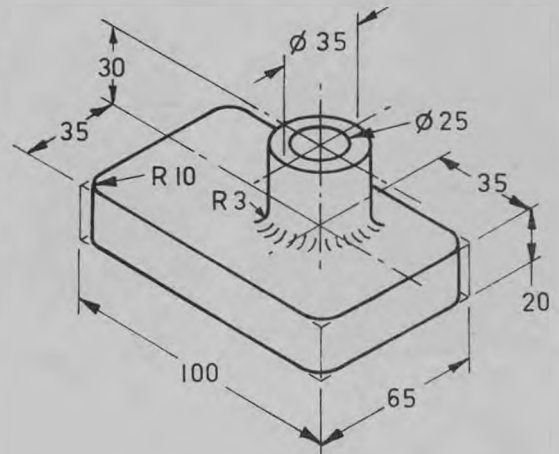

Fig. 6.23. INTERSECTIONS

AMDT Page 74. Fig. 6.25.
No 1
APR. Delete existing figure (a) and substitute :
1987



(a) UNIDIRECTIONAL

AMDT Page 77. Fig. 6.36.
No 1
APR. Delete existing figure and substitute :
1987

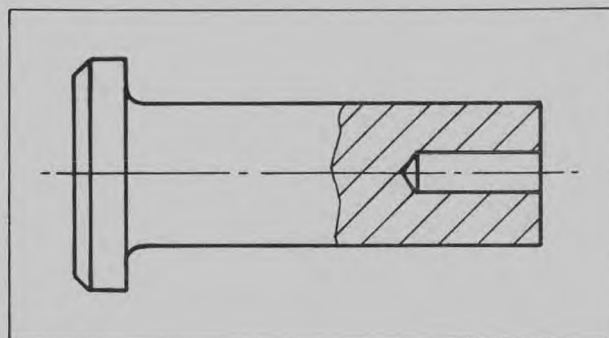

Fig. 6.36. LOCAL OR PART SECTION

AMDT No 1 APR. 1987 **Page 80. Fig. 6.44.**
Delete existing figure and substitute:

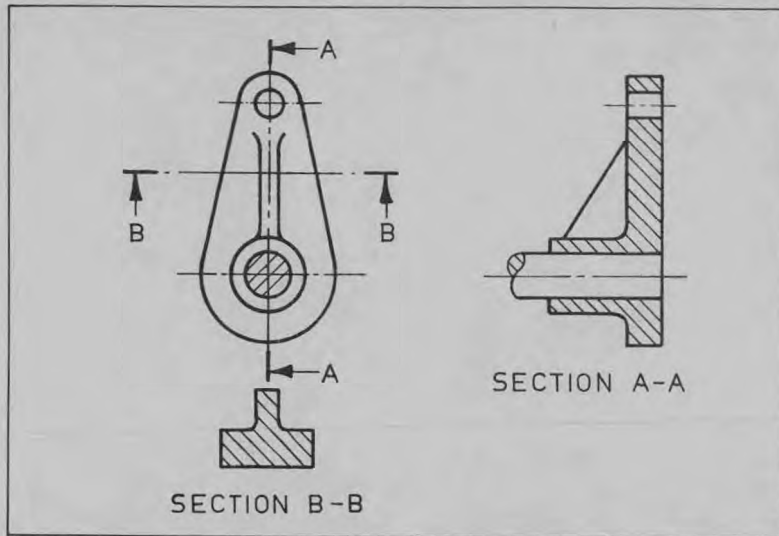

Fig. 6.44. WEB IN LONGITUDINAL SECTION NOT HATCHED

AMDT No 1 APR. 1987 **Page 85. Paragraph B3.2.**
 First line: delete ' $\alpha = \beta + 30^\circ$ ' and substitute ' $\alpha = \beta = 30^\circ$ '.
 Second line: delete ' $\sqrt{(2/3)}$ ' and substitute ' $\sqrt{2/3}$ '.

AMDT No 1 APR. 1987 **Page 85. Paragraph B3.3.**
Delete existing paragraph and substitute:

B3.3 Dimetric.

Select $\alpha + 2\beta = 90^\circ$ or $\alpha = \beta$ or $2\alpha + \beta = 90^\circ$, provided that $\alpha \neq 30^\circ$ and $\beta \neq 30^\circ$.

In particular, select $\alpha = \arctan \sqrt{(1/63)}$ and $\beta = \arctan \sqrt{(7/9)}$; i.e. $\alpha = 7^\circ$ approximately and $\beta = 41.5^\circ$ approximately to achieve the desired X:Y:Z ratio.

Then actual scales are $\sqrt{(8/9)}$, $\sqrt{(8/9)}$ and $\sqrt{(2/9)}$; i.e. 0.943, 0.943 and 0.471.

\therefore X:Y:Z = 1:1:0.5.

AMDT No 1 APR. 1987 **Page 86. Paragraph C2.**
 Third paragraph, last line: delete ' $r = a \cot \theta$ ' and substitute ' $r = a \cot \theta'$ '.
 Seventh paragraph: delete ' $\theta = \cot^{-1} 1$ ' and substitute ' $\theta = \operatorname{arccot} 1$ '.
 Eighth paragraph: delete ' $\theta = \cot^{-1} 0.5$ ' and substitute ' $\theta = \operatorname{arccot} 0.5$ '.
 Last paragraph: delete ' $\theta = \cot^{-1} R$ ' and substitute ' $\theta = \operatorname{arccot} R$ '.

File with AS 1100

Standards Association of Australia

INCORPORATED BY ROYAL CHARTER



HEAD OFFICE: STANDARDS HOUSE, 80 ARTHUR STREET, NORTH SYDNEY, N.S.W.

Mail: P.O. BOX 458,
NORTH SYDNEY, N.S.W. 2060
Telephone: 929 6022
Telegrams: Austandard North Sydney
Telex: 26514

Your reference:
Our reference: ERJ/rjw

1982-11-24

Dear Customer

We note from your recent order that you have requested a copy of AS CZ1, Australian Engineering Drawing Handbook published by the Institution of Engineers, Australia, and advise that the publication is no longer available from SAA sales outlets. We would refer you to the following notice which appeared in the December issue of "The Australian Standard" -

DRAWING PRACTICE -

AS 1100 supersedes AS CZ1 - *Part 1 & 2*

For some time there have been two Australian standards relating to drawing practice: AS CZ1, Australian Engineering Drawing Handbook (published by the Institution of Engineers, Australia, and first endorsed by SAA in 1941), and AS 1100, Drawing Practice.

The IEA handbook was first published in 1926 and SAA's endorsement of the 1941 (and subsequent) editions emphasized the national significance of the book. Thus, until the early 1970s, AS CZ1 was rightly regarded as the 'standard' textbook on engineering drawing practice. However, by that time, ISO had published a number of international standards on drawing practice, and SAA was thus in a position to produce an Australian standard which would both take account of the ISO work and provide for the change to metric. - this standard was published as AS 1100. SAA recognized, however, that there was a need to supplement AS 1100 with additional information, e.g. drafting advice, examples, and it was acknowledged that the IEA handbook admirably filled this role and should continue therefore to be an Australian standard.

The Institution of Engineers has just produced a new edition of Australian Engineering Drawing Handbook, but primarily because of the revision and consolidation of AS 1100 that is now in hand, this edition of the handbook has not been endorsed as an Australian standard under the AS CZ1 designation, and will not be available from SAA sales outlets.

AS 1100 will shortly be reissued in three volumes to replace the existing 13 Parts. The new general title of AS 1100 will be 'Technical Drawing' and the three volumes will cover General Principles, Mechanical Drawing, and Architectural Drawing (the present Part 13). A fourth part is being prepared to deal with 'Engineering Survey and Design Drawing'.

Yours faithfully

G.M. Esgate
SALES MANAGER

Dear Cath

As per the letter I spoke about. It is an extract from Dec. T.A.S.

It should read

Part 13

Association Member:
INTERNATIONAL ORGANIZATION FOR STANDARDIZATION and INTERNATIONAL ELECTRO-TECHNICAL COMMISSION

*
ASTAN AA33877
ASTAN AA26514

TX 1322

1986-04-03

4.00 P.M.

ATTENTION: MR R RAPHAEL.

RE: YOUR TELEX 1986-04-03.

TABLE 2.7 IS CORRECTIN AS 1100. 101. POINT OUT TO INQUIRER THAT
TABLE REFERS TOZONES. LETTER M IS CORRECT AS THERE ARE 12 HORIZONTAL
ZONES WITH LETTER I OMITTED REFER CLAUSE 2.4.4(B).

REGARDS,

REX BLATCHFORD.

*
ASTAN AA33877
ASTAN AA26514

GA
26514
ASTAN AA26514
ASTAN AA33877

ATT: MR. R. BLATCHFORD

HAVE RECEIVED INQUIRY RE. AS 1100.101-1984, TABLE 2.7. INQUIRER FEELS FIRST ITEM IN COLUMN ONE UNDER DETAIL SHOULD READ DESIGNATED A, B FOR VERTICAL AND ...1, 2 FOR HORIZONTAL AS IN FIG 2.5 AND 2.6. ALSO, RE FIG 2.5 AND 2.6., ANOTHER INQUIRER WONDERS WHERE LETTER 'M' SHOULD BE LETTER 'L'. CAN YOU ADVISE PLEASE.

TKS AND REGARDS

RAE RAPHAEL
MIC
1986-04-03:1355

*
ASTAN AA26514
ASTAN AA33877

AUSTRALIAN STANDARD

**TECHNICAL DRAWING
Part 101
GENERAL PRINCIPLES**

AS 1100, Part 101—1984

First published (as AS 1100, Parts 1 to 8) 1971 to 1980 AS 1100, Part 101 first published 1984

**PUBLISHED BY THE STANDARDS ASSOCIATION OF AUSTRALIA
STANDARDS HOUSE, 80 ARTHUR ST, NORTH SYDNEY, N.S.W.**

ISBN 0 7262 3165 7

PREFACE

This standard was prepared by the Association's Committee on Technical Drawing. It represents a revision and consolidation of AS 1100, Parts 1 to 8—1971 to 1980.

It constitutes Part 101 of a new multi-part standard designated AS 1100, Technical Drawing, which supersedes Parts 1 to 12 of the 13-part standard AS 1100, Drawing Practice.

Concurrent with this Part 101, Parts 201 and 401 are also published, viz:

Part 201—Mechanical Drawing

Part 401—Engineering Survey and Engineering Survey Design Drawing

Part 301 of this standard, Architectural Drawing, is in course of preparation and until such time as it is published, AS 1100, Part 13—1978, Architectural Drawing, will remain current.

It was in 1976 that the above committee decided that rather than have a standard of many parts it would be better if all aspects of technical drawing were consolidated into fewer parts that would embrace the entire discipline.

The designation AS 1100 has been retained for this new multi-part standard since it is already well established throughout industry and technical colleges as the Australian standard number for technical drawing. However, to identify these new editions from the previous ones, the designation of 3-digit Part numbers has been employed.

In the preparation of this standard, the committee took account of changes in Australian technical drawing practice and recommendations of the International Organization for Standardization (ISO, see below). Also considered were the equivalent British, American and Canadian standards.

In its preparation many minor changes in the layout of the text and figures have taken place resulting in greater consistency and improved ease of use of the document.

Another improvement to the overall usefulness of the final standard is in the provision of a comprehensive contents list which will simplify the finding of required text and figures.

The committee also considers it important that this document will be applicable to all sectors of the technical field. For instance, although many of the examples are of a mechanical nature, the principles are applicable to all fields of technical drawing. Accordingly, wherever necessary, examples have been expanded to show other applications of the principles.

Much consideration was given to the increasing use of stencil and mechanical means of producing characters and symbols. The inclusion of further requirements on machine-made lettering will depend largely on developments of the various equipments and their availability and use in Australia. However, it must be emphasized that the recommendations herein are flexible enough to allow conformity, provided that the basic rules are followed:

The requirements of this standard will ensure that micrographic and reprographic requirements are complied with.

Clarity of expression in defining the designer's requirements and in the interpretation of these requirements has been considered at all times. The introduction of symbols now plays an important part in drawing practice so that language barriers in reading drawings are reduced to a minimum and valuable drafting time inserting notes is minimized.

The requirements of this standard were based on a number of ISO documents. They are as follows:

- ISO R 128 ^{Technical} ~~Engineering~~ Drawings—Principles of Presentation ^{General}
- ISO R 129 Engineering Drawing—Dimensioning
- ISO R 406 ^{Technical Drawings -} ~~Inscription of~~ Linear and Angular Tolerances ^{Indications on Drawings}
- ISO R 1101 ^{Technical Drawings -} ~~Technical Drawings -~~ ^{Geometrical Tolerancing - Tolerancing of Form, orientation, location and run-out - generalities} Part 1—Generalities, Symbols, Indications on Drawings ^{and run-out - generalities definitions, symbols, ind.}
- ISO 3098/1 ^{Technical Drawings -} ~~Technical Drawings -~~ Lettering, Part 1—Currently Used Characters ^{on drawings}

see
AMDT 1.

Acknowledgement is made of the assistance obtained from the following British standard:

BS 1192:1969 Recommendations for Building Drawing Practice

©Copyright — STANDARDS ASSOCIATION OF AUSTRALIA 1984
 Users of standards are reminded that copyright subsists in all SAA publications. No part of this publication may be reproduced, stored in a retrieval system in any form or transmitted by any means without prior permission in writing of the Standards Association of Australia.

CONTENTS

	<i>Page</i>
SECTION 1. SCOPE AND GENERAL	
1.1 Scope	7
1.2 Application	7
1.3 Referenced Documents.....	7
1.4 Terminology	8
1.5 Abbreviations.....	18
SECTION 2. MATERIALS, SIZES AND LAYOUT OF DRAWING SHEETS	
2.1 Scope of Section	27
2.2 Materials.....	27
2.3 Sizes of Sheets	27
2.4 Layout of Drawing Sheets	28
SECTION 3. LINES	
3.1 Types of Lines	42
3.2 Dimensions of Lines	43
3.3 Line Spacing	44
3.4 Line Density	44
3.5 Application of Lines	44
3.6 Special Applications of Lines	51
3.7 Order of Priority of Coincident Lines	52
SECTION 4. LETTERS, NUMERALS AND SYMBOLS	
4.1 Letters and Numerals	53
4.2 Item References	58
4.3 Symbols	59
SECTION 5. SCALES	
5.1 Scales	62
5.2 Indication of Scales	62
SECTION 6. PROJECTIONING AND SECTIONING	
6.1 Identification	63
6.2 Methods of Projection	63
6.3 Orthogonal Projection	63
6.4 Axonometric Projection	68
6.5 Oblique Projection.....	69
6.6 Perspective Projection	70
6.7 Other Details—Pictorial Drawings	73
6.8 Method of Indicating Sections	73
6.9 Hatching.....	73
6.10 Cutting Planes	76
6.11 Sectional Views and Sections	76
6.12 Other Conventions Used in Sectioning	79
APPENDICES	
A Pictorial Comparison of First and Third Angle Projection	82
B Axonometric Projection—Additional Information	83
C Oblique Projection—Angle of Line of Sight	86
INDEX	87
FIGURES	
1.1 Details	8
1.2 Types of Features	8
1.3 Typical Leaders	9
1.4 Orientation of Ideal Line or Surface Relative to the Actual Line or Surface	10

FIGURES

1.5	Sectional View	10
1.6	Axometric Projection	11
1.7	Oblique Projection	12
1.8	Example of Third Angle Projection (with Projection Symbol)	12
1.9	Perspective Projection	13
1.10	Datum, Datum Feature and Simulated Datum	13
1.11	Datum Dimension (Shown in Box)	14
1.12	Datum Group Established by Two Features	14
1.13	Examples of Dimensions	15
1.14	Overall Length Added as an Auxiliary Dimension	15
1.15	Basic Dimensions	16
1.16	Functional and Non-functional Dimensions	16
1.17	Local Size	17
1.18	Limits of Size	17
1.19	Bilateral Tolerance	18
1.20	Unilateral Tolerance	18
2.1	Size and Location of Drawing Frame on Drawing Sheets without Filing Margin (Dimensions are Nominal)	28
2.2	Size and Location of Drawing Frame on Drawing Sheets with Filing Margin (Dimensions are Nominal)	29
2.3	Dimensions of Drawing Frame: Roll Drawings	30
2.4	Oversize Drawing Sheet with Print Trimming Line Indication	30
2.5	Typical Camera Alignment Marks, Reference System and Fold Lines For Preferred Series Drawing Sheets	32
2.6	Typical Camera Alignment Marks, Reference System and Fold Lines For Non-preferred Series Drawing Sheets	33
2.7	Typical Layout of a Drawing Sheet (Without Parts List)	34
2.8	Typical Layout of a Drawing Sheet (With Parts Lists)	35
2.9	Typical Layout of a Drawing Sheet (With Alternative Location of Title Block and Parts List)	36
2.10	Typical Title Blocks	37
2.11	Typical Layout of a Parts List	38
2.12	Technical Data Sheet for Components—Electrotechnology	39
2.13	Technical Data Sheet for Relays—Electrotechnology	40
2.14	Technical Data Correlation Sheet—Electrotechnology	41
3.1	Line Groups	43
3.2	Typical Application of Types of Lines—Survey	45
3.3	Typical Application of Types of Lines—Mechanical	46
3.4	Typical Application of Types of Lines—Architectural	47
3.5	Typical Application of Types of Lines—Electrotechnology	48
3.6	Imaginary Intersection of Surfaces	49
3.7	Tangent Bend Lines	49
3.8	Part Section & 'S' Break Lines	49
3.9	Hidden Outline Techniques	50
3.10	Feature in Front of Cutting Plane	50
3.11	Material to be Removed	50
3.12	Surface to Meet Special Tolerance Requirements & Surface Treatment	50
3.13	Adjacent Part	51
3.14	Tool Shape in Outline	51
3.15	Indication of Flat Surfaces	51
3.16	Floor Openings	51
3.17	Lines of Symmetry	51
3.18	Order of Priority of Coincident Lines	52
4.1	Upright Gothic (Roman) Characters	54
4.2	Sloping Gothic (Italic) Characters	54
4.3	ISO 3098/1 Type B Upright Characters	55
4.4	ISO 3098/1 Type B Sloping Characters	56
4.5	Microfont Characters	56
4.6	Spacing of Characters	57

FIGURES

4.7	Characters Clear of Lines	57
4.8	Example of Decimal Form	57
4.9	Item References—Example	58
4.10	Numbers for Referring to Item Lists	59
4.11	Arrowheads	59
4.12	Leaders Terminating in Dots Within the Outlines	60
4.13	Leaders Terminating in Arrowheads Touching Outlines	60
4.14	Shape and Size of Symbols	60
6.1	Designation of Views	63
6.2	Example of Third Angle Projection (with Projection Symbol)	63
6.3	Example of First Angle Projection (with Projection Symbol)	64
6.4	Single View Drawings Suitably Dimensioned	64
6.5	Indication of View Deviating from Method of Projection	64
6.6	Examples of Partial Views	65
6.7	Auxiliary Views	65
6.8	Removed Views	66
6.9	Rounded Corners and Fillets...	66
6.10	Rounded and Filleted Intersections	67
6.11	Omission of Unnecessary Detail	67
6.12	Choice of Axonometric View	68
6.13	Isometric Drawing	68
6.14	Dimetric Drawing	69
6.15	Trimetric Drawing	69
6.16	Oblique Projection—Cavalier Type	69
6.17	Oblique Projection—Cabinet Type	70
6.18	Oblique Projection—General	70
6.19	General Principles of Perspective Projection	71
6.20	Perspective Drawing	72
6.21	Sectional Views and Hatching	73
6.22	Fillets and Rounds	73
6.23	Intersections	73
6.24	Representation of Threads	73
6.25	Dimensioning	74
6.26	Hatching	74
6.27	Hatching of Adjacent Parts	74
6.28	Hatching of Large Areas	74
6.29	Interruption of Hatching for Lettering	75
6.30	Hatching as Solid Area	75
6.31	Continuity of Hatching	75
6.32	Indication of Cutting Plane	76
6.33	Simplified Indication of Cutting Plane	76
6.34	Indication of Cutting Plane Omitted	76
6.35	Half Section	76
6.36	Local or Part Section	77
6.37	Aligned and Auxiliary Aligned Sectional Views	77
6.38	Revolved Sections	78
6.39	Interposed Sections	78
6.40	Removed Sections	78
6.41	Placement of Sectional Views	78
6.42	Placement of Successive Sections	79
6.43	Section with Axial Features	79
6.44	Web in Longitudinal Section not Hatched	80
6.45	Webs not Sectioned and Holes Shown in Plane of Section	80
6.46	Use of Break Lines on Elongated Objects	81

TABLES

1.1	Abbreviations—Encoding	19
1.2	Abbreviations—Decoding	23

TABLES

1.3	Chemical Elements	26
2.1	Dimensions of Preferred Sheets	27
2.2	Dimensions of Preferred Sheets (with Wider Borders)	27
2.3	Dimensions of Elongated Preferred Sheets	27
2.4	Dimensions of Non-preferred Sheets	27
2.5	Dimensions of Non-preferred Sheets (with Wider Borders)	27
2.6	Dimensions of Drawing Frame: Roll Drawings	30
2.7	Details of Grid References	30
2.8	Thickness of Format Lines	31
3.1	Lines and Applications	42
4.1	Minimum Height of Characters on Drawings	53
4.2	Dimensions of Symbols for Dimensioning and Tolerancing	61
4.3	Definition and Application of Symbols	61
5.1	Engineering Drawing Scales	62
5.2	Architectural and Building Scales	62
5.3	Surveying and Mapping Scales	62
6.1	Methods of Projection	63

STANDARDS ASSOCIATION OF AUSTRALIA

Australian Standard
for
TECHNICAL DRAWING
PART 101—GENERAL PRINCIPLES

SECTION 1. SCOPE AND GENERAL

1.1 SCOPE. This standard sets out the basic principles of technical drawing practice. It is in six sections as follows:

Section 1 explains the various words, terms and phrases used in technical drawing. The terms relate to types of objects and projects portrayed in technical drawings, the types of drawings, methods of projection, dimensions and tolerances that define the size of objects, and other related items.

The Section also provides information concerning abbreviations used in technical drawing.

Section 2 specifies materials, sizes and layout of drawing sheets.

Section 3 specifies the type and minimum thickness of lines to be used in technical drawing. It is equally applicable to ink and pencil linework. It shows typical examples of their application.

Section 4 sets out the provisions for distinct uniform letters, numerals and symbols used in technical drawing.

Section 5 specifies recommended scales for use in engineering drawings, for architectural and building drawings, and for surveying and mapping purposes.

Methods of indicating scales on drawings are also specified.

Section 6 specifies methods of projection and of indication of the various views of an object including sectional views.

Appendices provide information on the development of pictorial drawings for catalogues and similar purposes.

1.2 APPLICATION. The basic principles given in this standard are intended for adoption by engineers, architects, surveyors, draughtsmen and technologists in the preparation and interpretation of technical drawings, diagrams and charts for the purpose of conveying technical information.

Technical drawings may include such drawings as:

- Detail drawings
- Assembly drawings
- Plans
- Illustrations
- Schematic diagrams
- Pictorial drawings
- Installation drawings

1.3 REFERENCED DOCUMENTS. The following standards are referred to in this standard:

- AS 1000 The International System of Units (SI) and its Application
- AS 1100 Technical Drawing
 - Part 201—1984 Mechanical Drawing
 - Part 401—1984 Engineering Survey and Engineering Survey Design Drawing
 - Part 13—1978 Architectural Drawing
- AS 1101 Graphical Symbols for General Engineering
- AS 1102 Graphical Symbols for Electrotechnology
- AS 1203 Microfilming of Engineering Documents (35 mm)
- AS 1654 Limits and Fits for Engineering
- AS 2536 Surface Texture
- ISO 3098 Technical Drawings—Lettering
 - Part 1—Currently Used Characters