

Australian/New Zealand Standard™

**Demand response capabilities and
supporting technologies for electrical
products**

**Part 3.3: Interaction of demand
response enabling devices and
electrical products—Operational
instructions and connections for electric
storage and electric-boosted storage
water heaters**



AS/NZS 4755.3.3:2014

This Joint Australian/New Zealand Standard was prepared by Joint Technical Committee EL-054, Remote Demand Response of Electrical Products. It was approved on behalf of the Council of Standards Australia on 10 December 2013 and on behalf of the Council of Standards New Zealand on 12 December 2013. This Standard was published on 17 January 2014.

The following are represented on Committee EL-054:

Airconditioning and Refrigeration Equipment Manufacturers Association of Australia
Australian Industry Group
Clean Energy Council
Consumer Electronics Suppliers Association
Consumers Federation of Australia
Copper Development Centre, Australia
CSIRO
Department of Industry (Commonwealth)
Electricity Engineers Association, New Zealand
Electricity Networks Association, New Zealand
Energy Networks Association
Heating, Ventilation and Air Conditioning, New Zealand
Smart Grid Australia
Swimming Pool and Spa Association of Australia

Keeping Standards up-to-date

Standards are living documents which reflect progress in science, technology and systems. To maintain their currency, all Standards are periodically reviewed, and new editions are published. Between editions, amendments may be issued. Standards may also be withdrawn. It is important that readers assure themselves they are using a current Standard, which should include any amendments which may have been published since the Standard was purchased.

Detailed information about joint Australian/New Zealand Standards can be found by visiting the Standards Web Shop at www.saiglobal.com.au or Standards New Zealand web site at www.standards.co.nz and looking up the relevant Standard in the on-line catalogue.

For more frequent listings or notification of revisions, amendments and withdrawals, Standards Australia and Standards New Zealand offer a number of update options. For information about these services, users should contact their respective national Standards organization.

We also welcome suggestions for improvement in our Standards, and especially encourage readers to notify us immediately of any apparent inaccuracies or ambiguities. Please address your comments to the Chief Executive of either Standards Australia or Standards New Zealand at the address shown on the back cover.

Australian/New Zealand Standard™

Demand response capabilities and supporting technologies for electrical products

Part 3.3: Interaction of demand response enabling devices and electrical products—Operational instructions and connections for electric storage and electric-boosted storage water heaters

First published as AS/NZS 4755.3.3:2014.

COPYRIGHT

© Standards Australia Limited/Standards New Zealand

All rights are reserved. No part of this work may be reproduced or copied in any form or by any means, electronic or mechanical, including photocopying, without the written permission of the publisher, unless otherwise permitted under the Copyright Act 1968 (Australia) or the Copyright Act 1994 (New Zealand).

Jointly published by SAI Global Limited under licence from Standards Australia Limited, GPO Box 476, Sydney, NSW 2001 and by Standards New Zealand, Private Bag 2439, Wellington 6140.

PREFACE

This Standard was produced by the Joint Standards Australia/Standards New Zealand Committee EL-054, Remote Demand Response of Electrical Products.

This Standard forms part of a series of Standards that is intended to define the nomenclature, architecture and operational instructions for systems that can be used to remotely control electrical products, and to define the demand response capabilities of electrical products. AS 4755—2007, *Framework for demand response capabilities and supporting technologies for electrical products*, will have its title and designation changed by amendment to become AS/NZS 4755.1. When complete, the series will comprise the following:

AS

4755 Demand response capabilities and supporting technologies for electrical products

4755.1 Part 1: Framework for demand response capabilities and requirements for demand response enabling devices (DREDS)

4755.3.1 Part 3.1: Interaction of demand response enabling devices and electrical products—Operational instructions and connections for air conditioners

4755.3.2 Part 3.2: Interaction of demand response enabling devices and electrical products—Operational instructions and connections for devices controlling swimming pool pump-units

4755.3.3 Part 3.3: Interaction of demand response enabling devices and electrical products—Operational instructions and connections for electric storage and electric-boosted storage water heaters (this Standard)

4755.3.4 Part 3.4: Interaction of demand response enabling devices and electrical products—Operational instructions and connections for grid-connected charge/discharge controllers for electric vehicles

The diagram below depicts the scope of this Standard, AS 4755.3.3. This Standard addresses only the interaction of electric and electric-boosted storage water heaters and demand response enabling devices (DREDS). Other attributes of electric and electric-boosted storage water heaters, such as construction and performance, are addressed in other standards.

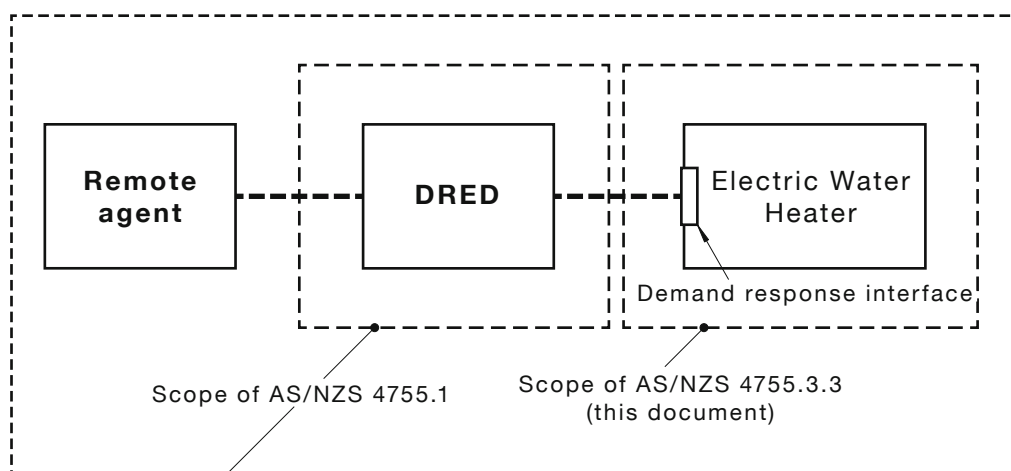

It is recommended that this Standard be read in conjunction with AS/NZS 4755.1.

The AS/NZS 4755 series creates a framework that will allow off-the-shelf equipment, communications technologies and electrical products to be integrated and adapted so that demand management solutions may be developed and deployed in a timely and economical fashion.

Although the Standards have been developed to support situations where demand response is initiated or managed by a remote agent, with the consent of the owner or user of the electrical product, the demand response interface also provides the technical capability for the owner or user to take direct responsibility for demand response, by managing the DRED independently of any remote agent, provided the DRED meets the requirements of AS/NZS 4755.1.

This Standard pertains to a particular electrical product, the electric or electric-booster storage water heater. The Standard specifies, for electric storage and electric-booster storage water heaters,—

- (a) a standard demand response interface;
- (b) a standard set of operational instructions;
- (c) the markings to be applied to products complying with the Standard; and
- (d) the methods of testing to verify compliance.

Detailed standards covering demand response operational instructions and interfaces with DREDS for other electrical products may also be prepared as needs are identified.

This Standard is intended to support demand response programs that optimize the operation of the electricity supply system and allow the efficient planning and use of capital equipment, while minimizing the risks to the comfort and amenity of electric or electric-booster storage water heater users.

Statements expressed in mandatory terms in notes to tables and figures are deemed to be requirements of this Standard.

The terms 'normative' and 'informative' have been used in this Standard to define the application of the appendix to which they apply. A 'normative' appendix is an integral part of a Standard, whereas an 'informative' appendix is only for information and guidance.

CONTENTS

	<i>Page</i>
SECTION 1 SCOPE AND GENERAL	
1.1 SCOPE.....	5
1.2 REFERENCED DOCUMENTS.....	6
1.3 DEFINITIONS.....	6
SECTION 2 OPERATIONAL INSTRUCTIONS AND DEMAND RESPONSE MODES	
2.1 GENERAL PRINCIPLES.....	10
2.2 DEMAND RESPONSE MODES.....	10
2.3 MANUAL OVERRIDE.....	13
2.4 AUTOMATIC OVERRIDE.....	13
2.5 RESPONSE TIMES.....	13
2.6 OPERATION OF AUXILIARY EQUIPMENT.....	13
2.7 MULTIPLE OPERATIONAL INSTRUCTIONS.....	13
SECTION 3 INTERFACES	
3.1 GENERAL.....	14
3.2 PHYSICAL INTERFACES.....	14
3.3 RJ45 SOCKET.....	14
3.4 TERMINAL BLOCK.....	15
3.5 CIRCUIT TO DRED.....	16
3.6 OPTIONAL 230 V AC POWER SUPPLY.....	17
3.7 OPTIONAL EXTRA-LOW VOLTAGE POWER SUPPLY.....	17
3.8 LOCATION AND ACCESS.....	17
SECTION 4 LABELLING AND MARKING OF DEMAND RESPONSE CAPABILITY	
4.1 GENERAL.....	18
4.2 REGISTRATION.....	18
4.3 POINT OF SALE LABELLING.....	18
4.4 MARKING.....	19
4.5 DOCUMENTATION.....	19
SECTION 5 VERIFICATION OF CLAIMED DEMAND RESPONSE CAPABILITY	
5.1 SET-UP FOR TESTING.....	20
5.2 TESTING RESPONSES TO OPERATING INSTRUCTIONS.....	20
5.3 NON-COMPLIANCE.....	21
5.4 VERIFICATION OF CLAIMED COMPLIANCE WITH DRM 1.....	21
5.5 VERIFICATION OF CLAIMED COMPLIANCE WITH DRM 2.....	22
5.6 VERIFICATION OF CLAIMED COMPLIANCE WITH DRM 3.....	23
5.7 VERIFICATION OF CLAIMED COMPLIANCE WITH DRM 4.....	23
APPENDICES	
A REGISTRATION INFORMATION FOR WATER HEATERS COMPLYING WITH AS/NZS 4755.3.3.....	25
B VERIFICATION OF CLAIMED DEMAND RESPONSE CAPABILITY FOR WATER HEATERS.....	27
C EXAMPLE OF CIRCUIT WITH 6 PIN CONNECTIONS.....	31

STANDARDS AUSTRALIA/STANDARDS NEW ZEALAND

Australian/New Zealand Standard

Demand response capabilities and supporting technologies for electrical products

Part 3.3: Interaction of demand response enabling devices and electrical products—Operational instructions and connections for electric storage and electric-boosted storage water heaters

S E C T I O N 1 S C O P E A N D G E N E R A L

1.1 SCOPE

This Standard—

- (a) applies to electric storage water heaters that do not contain a DRED, and have a demand response interface intended to connect with a DRED;
- (b) specifies a set of operational instructions that will meet the requirements of remote agents wishing to control the energy consumption of electric and electric boosted water heaters; and
- (c) specifies two alternative methods of connecting the demand response interface to the DRED.

An electric storage water heater (whether using electric resistive heating, heat pump water heating, solar water heating or a combination of these) is covered by this Standard if it has—

- (i) a nominal capacity between 10 L and 710 L;
- (ii) one or more resistive heating elements and a rated electrical power of 7.2 kW or less; or
- (iii) no resistive heating element and a rated electrical power of 2 kW or less.

Heat exchange water heaters meeting the above criteria are also covered by this Standard.

The following water heaters are not covered by this Standard:

- (A) Gas water heaters.
- (B) Instantaneous water heaters.
- (C) Boiling water dispensers.
- (D) Steam generators.
- (E) Sterilizers.
- (F) Urns.
- (G) Kettles.
- (H) Hot water supply systems intended solely for space heating or for swimming pool, spa pool or industrial process heating.