

1056 Storage water heaters
1056.3—1991 Specific requirements for water
heaters with composite shells
(In Professional Packages 30, 50E, 61) A4 13pp E
Specifies constructional requirements for water containers
(shells) made of composite materials, viz. steel with a copper
or copper alloy insert (inner liner), or steel with a bonded inner
lining of vitreous enamel or of plastics material. Gives
recommendations on maximum water temperatures, specifies
methods of testing the quality of inner linings, and also routine
and type test schedules.
Committee EL/20. Supersedes AS 1056.3—1985. Publication date 1991-03-28:
ISBN 0 7262 6769 4

AS 1056.3—1985
UDC 621.365:683.97

Australian Standard[®] 1056.3—1985

STORAGE WATER HEATERS Part 3—SPECIFIC REQUIREMENTS FOR WATER HEATERS WITH COMPOSITE SHELLS



[Title allocated by the Defence Cataloguing Authority:
HEATER, WATER, ELECTRIC (Storage Type, Composite Shell)
NSC 4410, 4520]



STANDARDS ASSOCIATION OF AUSTRALIA
Incorporated by Royal Charter

This Australian standard was prepared by Committee EL/20, Electrical Water Heating Appliances. It was approved on behalf of the Council of the Standards Association of Australia on 12 February 1985, and published on 10 May 1985.

The following interests are represented on Committee EL/20:

- Australian Consumers Association
- Australian Electrical and Electronic Manufacturers' Association
- Australian Gas Association
- Confederation of Australian Industry
- Electricity Supply Association of Australia
- Engineering and Water Supply Department, South Australia

Representatives of the following interests also participated in the drafting of this Standard:

- Material Suppliers
-

Review of Australian Standards. To keep abreast of progress in industry, Australian standards are subject to periodic review and are kept up-to-date by the issue of amendments or new editions as necessary. It is important therefore that standards users ensure that they are in possession of the latest edition, and any amendments thereto.

Full details of all SAA publications will be found in the Catalogue of SAA Publications; this information is supplemented each month by SAA's journal 'The Australian Standard', which subscribing members receive, and which gives details of new publications, new editions and amendments, and of withdrawn standards.

Suggestions for improvements to Australian standards, addressed to the head office of the Association, are welcomed. Notification of any inaccuracy or ambiguity found in an Australian standard should be made without delay in order that the matter may be investigated and appropriate action taken.

This standard was issued in draft form for comment as DR 84056.

AUSTRALIAN STANDARD

STORAGE WATER HEATERS
Part 3
SPECIFIC REQUIREMENTS FOR
WATER HEATERS WITH
COMPOSITE SHELLS

AS 1056.3—1985

First published (as AS C316)	1957
Revised	1965
Revised	1970
AS 1056 First published	1972
Revised	1977
AS 1056.3 first published	1985

PUBLISHED BY THE STANDARDS ASSOCIATION OF AUSTRALIA
STANDARDS HOUSE, 80 ARTHUR ST, NORTH SYDNEY, N.S.W.

ISBN 0 7262 3733 7

PREFACE

This standard was prepared by the Association's Committee on Electric Water Heating Appliances, to supersede (in part) AS 1056—1977, Automatic Electric Storage Water Heaters with Hot Water Deliveries Ranging from 25 Litres to 630 Litres. It is one of a series of standards covering storage water heaters, the other standards in the series being as follows:

- AS 1056.1 Storage Water Heaters, Part 1—General Requirements
 AS 1056.2 Storage Water Heaters, Part 2—Specific Requirements for Water Heaters with Single Shells

Other standards dealing with water heaters are as follows:

- AS 1308 Thermostats and Over-temperature Energy Cutouts for Automatic Electric Water Heaters
 AS 1357 Water Fittings for Protection and Control of Unvented Storage Water Heaters
 AS 1361 Automatic Electric Heat Exchange Water Heaters
 AS 1529 Code of Practice for Installation of Household Type Hot Water Supply Systems
 AS 2002 The Installation of Household Type Solar Hot Water Supply Systems
 AS 2123 Slow-delivery Type Automatic Electric Storage Water Heaters for Dairies
 AS 2712 Solar Water Heaters—Design and Construction

This standard differs from AS 1056—1977 in the following respects:

- (a) Linings of hot-dip bonded zinc have been deleted because of lack of use.
- (b) A bonded hot-water-stable plastics lining is now included.
- (c) A bonded vitreous enamel lining of lower solubility intended for use at higher water temperatures is now included.
- (d) An additional requirement is now included which limits defects in the enamel caused by welding of shells after vitreous enamel lining (see Clause 5.4.3).

CONTENTS

	<i>Page</i>
SPECIFICATION	
1 Scope	3
2 Application	3
3 Referenced Documents	3
4 Shells with Metallic Inserts	3
5 Bonded Vitreous Enamelled Shells	4
6 Bonded Plastics-lined Shells	6
7 Thermostat Settings	7
8 Determination of Compliance	7
APPENDICES	
A Method for the Determination of the Solubility of Vitreous Enamel Lining	8
B Method for the Determination of the Resistance to Oxygen of Bonded Plastics Linings	11
C Method for the Determination of the Resistance to Thermal Shock of Bonded Plastics Linings	13
D Method for the Determination of the Resistance to Thermal Cycling of Bonded Plastics-lined Shells	15

©Copyright — STANDARDS ASSOCIATION OF AUSTRALIA 1985

Users of standards are reminded that copyright subsists in all SAA publications. No part of this publication may be reproduced, stored in a retrieval system in any form or transmitted by any means without prior permission in writing of the Standards Association of Australia.

STANDARDS ASSOCIATION OF AUSTRALIA

AUSTRALIAN STANDARD
for
STORAGE WATER HEATERS

**PART 3—SPECIFIC REQUIREMENTS FOR WATER HEATERS
WITH COMPOSITE SHELLS**

1 SCOPE. This standard specifies requirements for water heaters with composite shells made from steel and protected as follows:

- (a) With a metallic insert.
- (b) With a bonded vitreous enamel lining.
- (c) With bonded plastics lining.

2 APPLICATION. The requirements of this standard are in addition to those in AS 1056.1.

3 REFERENCED DOCUMENTS. The following standards are referred to in this standard:

- AS 1056.1 Storage Water Heaters
Part 1—General Requirements
- AS 1449 Wrought Alloy Steels—Stainless and Heat-resisting Steel Plate, Sheet and Strip
- AS 1566 Copper and Copper Alloy Plate, Rolled Bar, Sheet, Strip and Foil for General Engineering Purposes
- AS 1627 Code of Practice for Preparation and Pretreatment of Metal Surfaces Prior to Protective Coating
Part 4—Abrasive Blast Cleaning of Steel Surfaces
Part 9—Pictorial Surface Preparation Standards for Painting Steel Surfaces
- AS Z5 Glossary of Metal Welding Terms and Definitions
Part 1—General Terms for Welding, Brazing and Cutting*

4 SHELLS WITH METALLIC INSERTS.

4.1 Non-ferrous metallic insert.

4.1.1 Material. The insert shall be made from one of the following materials complying with AS 1566:

- (a) Silicon bronze alloy A, Designation AS 1566/655.
- (b) 90/10 copper-nickel, Designation AS 1566/706.
- (c) Phosphorous deoxidized copper, high residual phosphorous, Designation AS 1566/122.

NOTE: Other materials may be considered by SAA Committee EL/20 for possible inclusion in this draft on production of satisfactory evidence of long-term suitability for purpose.

4.1.2 Thickness. When checked at 20 representative points on the walls and ends, the insert shall have a thickness of not less than 0.50 mm.

4.1.3 Conformity with steel shell. The insert shall be in virtually intimate contact with the steel shell over its entire surface.

4.2 Steel shell. The shell shall be made from a grade of steel that will consistently ensure satisfactory jointing with the insert.

4.3 Jointing.

4.3.1 Welding of the shell. The welds shall be of a quality not inferior to that produced by the submerged-arc process. The longitudinal seam shall be butt welded.

Weld beads and edges against which the insert will bear shall be finished so that local stresses are not imposed upon the metallic insert.

4.3.2 Jointing of the insert. Joints in the insert shall be either welded or brazed. The jointing shall be finished so that intimate contact with the steel is ensured.

4.4 Watertightness. Where tested with water at the maximum working pressure, the insert shall not leak. Where a shell has opening(s) for the expulsion of air from the interspace or for the detection of leaks, these opening(s) shall be sealed at the conclusion of this test and while the shell is subjected to pressure.

To provide access to the interspace, shells intended for type testing shall be fitted with at least three sealable openings of 3 mm to 5 mm diameter (see Fig. 1).

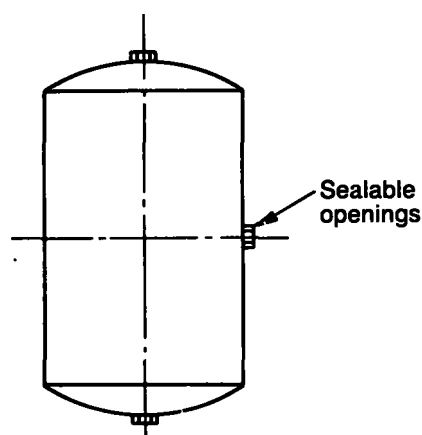

Fig. 1. OPENINGS IN CONTAINER

* In course of revision (see DR 83249)