

Superseded by
AS 1133:1996

DR 95081
1996 ed
FWD 960124
AS 1133—1985
UDC 677.31:617.017.224.3

Australian Standard® 1133—1985

• Amendments
1 to 1133—1985 Method for the determination of fibre
diameter of raw wool A
Committee TX/20. Publication date, 1985-02-03.

WOOL—DETERMINATION OF THE MEAN FIBRE DIAMETER OF RAW WOOL

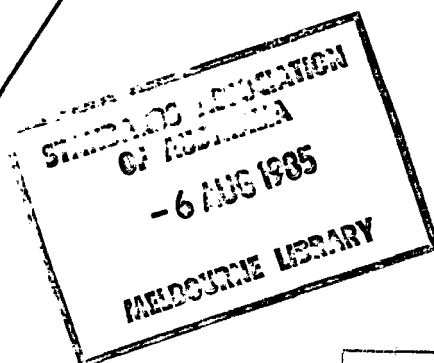

AS/NZS 1133:1996
Wool—Determination by the
Airflow Method of the mean
fibre diameter of core samples
of raw wool
(IWTO-28-93)
(In Professional Package 54H)
38pp H
Sets out a method for the
determination of the mean fibre
diameter of wool fibres sampled
from bales of raw wool by coring,
using cutters of nominal diameter
from 12 mm to 25 mm. It is
identical with and has been
reproduced from IWTO-28-93.
(TX/12): Supersedes AS 1133—1985;
DR 95081: Publication date 1996-04-05.



PUBLISHED BY THE STANDARDS ASSOCIATION OF AUSTRALIA
STANDARDS HOUSE, 80 ARTHUR ST, NORTH SYDNEY, N.S.W.

Incorporated by Royal Charter

This Australian standard was prepared by Committee TX/12, Testing of Wool. It was approved on behalf of the Council of the Standards Association of Australia on 8 February 1985, and published on 12 July 1985.

The following interests are represented on Committee TX/12:

Australian Council of Wool Buyers
Australian Wool Corporation
Australian Wool Testing Authority Ltd
CSIRO, Division of Textile Physics
Department of Defence
Department of Primary Industry
National Council of Wool Selling Brokers of Australia
University of New South Wales
Wool Council of Australia
Wool Scourers and Carbonizers Association of Australia
Wool Textile Manufacturers of Australia

Review of Australian Standards. To keep abreast of progress in industry, Australian standards are subject to periodic review and are kept up-to-date by the issue of amendments or new editions as necessary. It is important therefore that standards users ensure that they are in possession of the latest edition, and any amendments thereto.

Full details of all SAA publications will be found in the Catalogue of SAA Publications; this information is supplemented each month by SAA's journal 'The Australian Standard', which subscribing members receive, and which gives details of new publications, new editions and amendments, and of withdrawn standards.

Suggestions for improvements to Australian standards, addressed to the head office of the Association, are welcomed. Notification of any inaccuracy or ambiguity found in an Australian standard should be made without delay in order that the matter may be investigated and appropriate action taken.

AS 1133 first published.....	1971
AS 1401 first published.....	1973
AS 1133 and AS 1401 revised and issued as AS 1133.....	1985

This standard was issued in draft form for comment as DR 83177.

STANDARDS ASSOCIATION OF AUSTRALIA
Incorporated by Royal Charter

AMENDMENT No 1
to
AS 1133—1985
WOOL—DETERMINATION OF THE MEAN FIBRE DIAMETER OF RAW WOOL

REVISED TEXT

SUMMARY: This amendment applies to Clause 5.2 and Fig. A2.

Published on 3 February 1986.

AMDT
No 1
FEB.
1986

Page 6. Clause 5.2.

Delete existing Clause 5.2 and *substitute:*

5.2 Greasy wool—unprocessed wool from sheep or wool shorn from sheepskins.

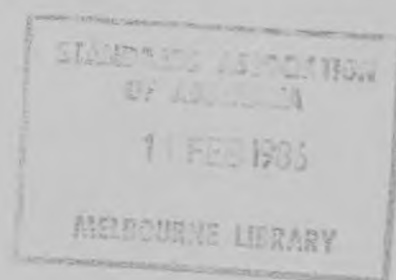

Delete existing Fig. A2 and Note and substitute:

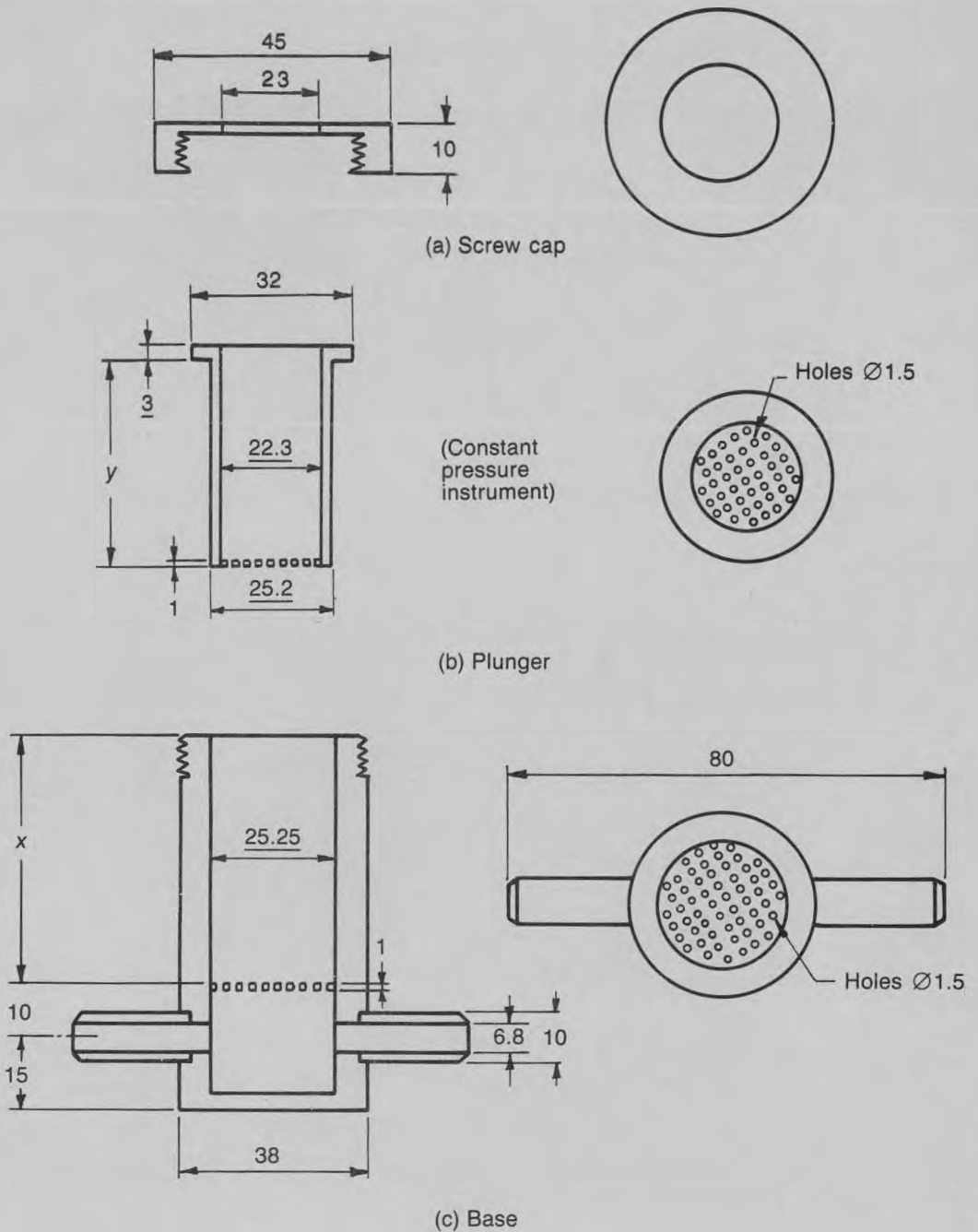

Height of constant volume chamber = $x - y = \underline{16.0 \pm 0.1}$

NOTE: x is about 51 mm in most current instruments. A large value of x , say 65 mm with a corresponding increase in the dimension y , has been found to facilitate packing.

DIMENSIONS IN MILLIMETRES. IMPORTANT DIMENSIONS ARE UNDERLINED

Fig. A2. CONSTANT VOLUME CHAMBER C

PREFACE

This standard was prepared by the Association's Committee on Testing of Wool under the direction of the Textile Standards Board. It supersedes AS 1133—1971, Determination of Fibre Diameter of Raw Wool, and AS 1401—1973, Sonic Fineness Testing of Raw Wool. The standard describes the airflow methods to be used for determining the mean fibre diameter of raw wool fibres sampled by coring methods. This standard embodies AS 1133—1971 which described the constant pressure airflow method and AS 1401—1973 which described a similar method but using sonic waves. Both methods measure the impedance to flow of air through a plug of wool fibre.

The revised procedures require that raw wool samples be drawn for testing in accordance with AS 1980. Scouring procedures prefer the use of non-ionic synthetic detergent at 70 °C. The standard provides for a single instrument or two instruments of the one type to be used for making one determination and permits the testing of two specimens (minimum), provided that the results are within a stated range.

The standard does not describe the constant-flow airflow method described in some international standards because this instrument is not used in Australia.

Calibration of both the airflow apparatus (constant-pressure) and the sonic fineness instrument with reference slivers cut into short lengths to simulate core samples is described.

The methods are similar but not identical to IWTO-28* and IWTO E-7†.

The standard is one of a series for sampling and testing wool. The other standards in the series are as follows:

- AS 1134 Method for the Determination of Wool Base and Vegetable Matter Base in Raw Wool
- AS 1362 Wool—Method for the Calculation of Combined Test Certificates for Yield and Fineness of Raw Wool in Consignments
- AS 1363 Wool—Grab Sampling of Greasy Wool
- AS 1809 The Preservation of the Integrity of Raw Wool Samples for Display
- AS 1980 Wool—Core Sampling of Raw Wool in Bales
- AS 2104 Method for Matching and Building Sale Lots of Greasy Wool in Bales by Objective Measurement
- AS 2274 Wool—Requirements for the Issue of a Test Certificate for Raw Wool
- AS 2720 Wool—Measurement of Mean Staple Length—Method Using the CSIRO Staple Length Meter
- AS 2721 Wool—Method for Subsampling of Staples from Grab Samples
- AS 2722 Wool—Determination of Mean Staple Strength—Method Using the CSIRO Staple Strength Meter
- AS XXXX Wool—Method for the Measurement of Clean Colour‡

* IWTO-28 Determination by the airflow method of the mean fibre diameter of core samples of raw wool

† IWTO E-7 Method for sonic fineness testing of raw wool

‡ In course of preparation.

©Copyright — STANDARDS ASSOCIATION OF AUSTRALIA 1985

Users of standards are reminded that copyright subsists in all SAA publications. No part of this publication may be reproduced, stored in a retrieval system in any form or transmitted by any means without prior permission in writing of the Standards Association of Australia.

CONTENTS

	<i>Page</i>
FOREWORD	5
METHOD	
1 Scope	6
2 Application	6
3 Referenced Documents	6
4 Principle	6
5 Definitions	6
6 Apparatus	6
7 Selection and Preparation of Test Specimens	6
8 Drying and Conditioning of the Laboratory Sample....	6
9 Calibration of Instrument	7
10 Measurement of Mean Fibre Diameter	7
11 Report	7
APPENDICES	
A Constant Pressure Airflow Instrument	8
B Sonic Fineness Instrument	15
C Special Types of Wool	20
D Sample Preparation with the Shirley Analyser (Wool Model)	21
E Precision Data	24

STANDARDS ASSOCIATION OF AUSTRALIA**Australian Standard
for****WOOL—DETERMINATION OF THE MEAN FIBRE DIAMETER OF RAW WOOL****FOREWORD**

The airflow technique of measuring wool fibre diameter* depends on the fact that, when air is caused to flow axially through a 'plug' of unmedullated compressed fibres there is a relationship between the resistance to flow and the mean diameter of the fibres constituting the plug. In the usual form of apparatus the flow resistance is determined by applying a known pressure differential across a sample and measuring the resultant rate of flow.

The departure of the sonic fineness instrument from the constant-pressure airflow instrument is that the former uses an alternating flow of air through the plug.†

As the method is indirect, each instrument must be calibrated with standard wools of known mean fibre diameter (see Clause 9).

The methods require that the fibres be clean and dispersed in a uniformly open state so that special preparation of raw wool is required. A suitable preparation and calibration method has been described‡. The measurements may be compared with other mean fibre diameter measurements if a correction is made for the effect of the coefficient of variation of the standard wools‡,§.

The mean fibre diameter of raw wool may not be the same as the mean fibre diameter of the resultant top. It is, however, possible for a mill to collect data and calculate a formula relating the two. The detailed form of the relationship is likely to vary from mill to mill.

* Anderson, S.L. and Warburton, F.G., *J. Text. Inst.* 40, T749, 1949

† Stearn, A.E., 'A Sonic Fineness Tester for Textile Fibres'. *J. Text. Inst.*, 61, 485, 1970

‡ James, J.F.P. and Bow, M.R., *J. Text. Inst.* 59, 485, 1968

§ James, J.F.P. and David, H.G., *J. Text. Inst.* 59, 585, 1968

METHOD

1 SCOPE. This standard sets out a method using two types of instruments described herein for determining the mean fibre diameter of wool fibres drawn from bales of raw wool by the core-sampling procedure described in AS 1980. It describes the procedures to be used to clean and prepare the wool sample prior to measurement.

2 APPLICATION. The standard is applicable to the measurement of raw wool as defined. On lambswool and heavily medullated wools, the method may give values which differ from those given by the projection microscope method (see Appendix C and AS 2001.2.1).

3 REFERENCED DOCUMENTS. The following standards are referred to in this standard:

AS 1134 Method for the Determination of Wool Base and Vegetable Matter Base in Raw Wool

AS 1980 Wool—Core Sampling of Raw Wool in Bales

AS 2001 Methods of Test for Textiles
2001.1 Conditioning Procedures
2001.2.1 Determination of Mean Fibre Diameter of Textile Fibres by the Projection Microscope

4 PRINCIPLE. A sample of raw wool is cleaned, if necessary, and prepared for measurement using the specified mechanical card.

The carded sample is brought to equilibrium with the standard testing atmosphere of $20 \pm 2^\circ\text{C}$ and 65 ± 2 percent r.h. and weighed test specimens are taken.

The test specimen is compressed to a fixed volume in a cylindrical chamber to form a plug of fibres. Air is moved through the plug of fibres causing a pressure difference across the plug. The mean diameter of the fibres in the test specimen is then determined from the impedance of the plug to the air moving through it, derived from a calibration previously carried out, using standard wools.

5 DEFINITIONS. For the purpose of this standard, the following definitions apply:

5.1 Core sample—the wool drawn by the core-sampling procedure given in AS 1980 from a lot or consignment of raw wool in bales.

~~**5.2 Greasy wool**—wool shorn from sheep or sheepskins which has not been scoured, solvent-degreased or carbonized.~~

5.3 Laboratory sample—the randomly drawn portion, representative of the scoured and dried subsample, to be carded and conditioned.

5.4 Raw wool—wool fibre together with variable amounts of vegetable matter and extraneous alkali-insoluble impurities, mineral matter, wool waxes, suint and moisture. It includes—

- (a) greasy wool;
- (b) wool which has been scoured, carbonized, washed or solvent-degreased;
- (c) scoured skin wools;
- (d) slipe wools.

5.5 Subsample—the randomly drawn portion, representative of the core sample, to be scoured and dried in accordance with AS 1134.

5.6 Test specimen—the randomly drawn portion weighing 2.500 ± 0.001 g, representative of the carded and conditioned laboratory sample, to be measured in the airflow apparatus.

6 APPARATUS.

6.1 Airflow instrument. An instrument of one of the following types:

- (a) The constant-pressure type airflow instrument and its accessories as described in Appendix A.
- (b) The sonic fineness instrument and its accessories as described in Appendix B.

6.2 Balance. A balance for weighing test specimens to 0.001 g.

6.3 Shirley analyser. A Shirley analyser (wool model) as described in Appendix D or similar mechanical card capable of homogenizing and fully opening the scoured laboratory sample, without excessive loss of wool, and eliminating dust and most of the vegetable matter.

6.4 Conditioning apparatus. A means of producing and maintaining the standard laboratory atmosphere of $20 \pm 2^\circ\text{C}$ and 65 ± 2 percent r.h., as described in AS 2001.1.

7 SELECTION AND PREPARATION OF TEST SPECIMENS.

7.1 Greasy and slipe wools. Laboratory samples of greasy and slipe wools shall be drawn from the scoured subsamples prepared for the determination of the wool content of raw wool in accordance with AS 1134. If the sample has been drawn for purposes of determining mean fibre diameter only, the sample shall be scoured and dried in accordance with AS 1134.

7.2 Scoured and carbonized wool. Laboratory samples shall be drawn from samples of scoured and carbonized wools obtained by coring methods without further treatment, except as described below.

7.3 Preparation of test specimens. Test specimens shall be prepared from laboratory samples selected and prepared as specified in Clauses 7.1 and 7.2 as follows:

- (a) From each of the scoured subsamples, draw at random approximately 10 g of wool.
- (b) If the alcohol extract of the laboratory sample drawn as specified in (a) exceeds 1.5 percent, when determined in accordance with AS 1134, degrease the laboratory sample so that it is within the limit.
- (c) Card the laboratory sample on the Shirley analyser in accordance with Appendix D.
- (d) Dry and condition the carded laboratory sample in accordance with Clause 8.
- (e) Using forceps, remove any excessive vegetable matter.
- (f) Draw at random test specimens weighing 2.500 ± 0.001 g from the conditioned, carded laboratory sample.

8 DRYING AND CONDITIONING OF THE LABORATORY SAMPLE. After carding (see Appendix D), ensure that the laboratory sample has

New
Clause 5.2
See
Amend. 1.