

Australian/New Zealand Standard™

**Demand response capabilities and
supporting technologies for electrical
products**

**Part 1: Demand response framework
and requirements for demand response
enabling devices (DREDs)**



AS/NZS 4755.1:2017

This Joint Australian/New Zealand Standard was prepared by Joint Technical Committee EL-054, Remote Demand Management of Electrical Products. It was approved on behalf of the Council of Standards Australia on 30 November 2016 and by the New Zealand Standards Approval Board on 9 February 2017. This Standard was published on 3 March 2017.

The following are represented on Committee EL-054:

Airconditioning and Refrigeration Equipment Manufacturers Association of Australia
Australian Industry Group
Clean Energy Council
Consumer Electronics Suppliers Association
Consumers Federation of Australia
CSIRO
Department of Industry, Innovation and Science, Australia
Electricity Engineers Association, New Zealand
Energy Efficiency and Conservation Authority of New Zealand
Energy Networks Association
Heating, Ventilation and Air Conditioning, New Zealand
International Copper Association, Australia
Smart Grid Australia
Swimming Pool and Spa Association of Australia

Keeping Standards up-to-date

Standards are living documents which reflect progress in science, technology and systems. To maintain their currency, all Standards are periodically reviewed, and new editions are published. Between editions, amendments may be issued. Standards may also be withdrawn. It is important that readers assure themselves they are using a current Standard, which should include any amendments which may have been published since the Standard was purchased.

Detailed information about joint Australian/New Zealand Standards can be found by visiting the Standards Web Shop at www.saiglobal.com or Standards New Zealand web site at www.standards.govt.nz and looking up the relevant Standard in the on-line catalogue.

For more frequent listings or notification of revisions, amendments and withdrawals, Standards Australia and Standards New Zealand offer a number of update options. For information about these services, users should contact their respective national Standards organization.

We also welcome suggestions for improvement in our Standards, and especially encourage readers to notify us immediately of any apparent inaccuracies or ambiguities. Please address your comments to the Chief Executive of Standards Australia or the New Zealand Standards Executive at the address shown on the back cover.

This Standard was issued in draft form for comment as DR AS/NZS 4755.1:2016.

Australian/New Zealand Standard™

Demand response capabilities and supporting technologies for electrical products

Part 1: Demand response framework and requirements for demand response enabling devices (DREDs)

Originated as AS 4755—2007.
Jointly revised and redesignated as AS/NZS 4755.1:2017.

COPYRIGHT

© Standards Australia Limited/Standards New Zealand

All rights are reserved. No part of this work may be reproduced or copied in any form or by any means, electronic or mechanical, including photocopying, without the written permission of the publisher, unless otherwise permitted under the Copyright Act 1968 (Australia) or the Copyright Act 1994 (New Zealand).

Jointly published by SAI Global Limited under licence from Standards Australia Limited, GPO Box 476, Sydney, NSW 2001 and by Standards New Zealand, PO Box 1473, Wellington 6011.

PREFACE

This Standard was prepared by the Joint Standards Australia/Standards New Zealand Committee EL-054, Remote Demand Management of Electrical Products, to supersede AS 4755—2007, *Framework for demand response capabilities and supporting technologies for electrical products*.

This Standard, together with the other parts of AS/NZS 4755, is intended to define the nomenclature, architecture and operational instructions for systems that can be used to remotely control electrical products. At the time of publication of this Part, the AS/NZS 4755 series comprises the following:

- 4755.1 Part 1: Framework for demand response capabilities and requirements for demand response enabling devices (DREDs)
- 4755.3.1 Part 3.1: Interaction of demand response enabling devices and electrical products—Operational instructions and connections for air conditioners
- 4755.3.2 Part 3.2: Interaction of demand response enabling devices and electrical products—Operational instructions and connections for devices controlling swimming pool pump-units
- 4755.3.3 Part 3.3: Interaction of demand response enabling devices and electrical products—Operational instructions and connections for electric and electric-boosted water heaters
- 4755.3.4 Part 3.4: Interaction of demand response enabling devices and electrical products—Operational instructions and connections for grid-connected charge/discharge controllers for electric vehicles (EVSEs) [proposed new Standard]
- 4755.3.5 Part 3.5: Interaction of demand response enabling devices and electrical products—Operational instructions and connections for grid-connected electrical energy storage (EES) systems

Note that there is currently no Part 2.

The AS/NZS 4755 Framework is also relevant to AS/NZS 4777, *Grid connection of energy systems via inverters*.

This Standard is intended to support demand response programs which optimize the operation of the electricity supply system and allow the efficient planning and use of capital equipment, while minimizing the risks to the comfort and amenity of the users of electrical products.

Demand response may be achieved in ways other than the AS/NZS 4755 framework. However, this Standard only covers the AS/NZS 4755 framework.

The following figure depicts the overall structure of AS/NZS 4755 and the place of AS/NZS 4755.1 within that structure.

All the information required to manufacture an electrical product which complies with AS/NZS 4755, Parts 3.1, 3.2, 3.3, 3.4 or 3.5 (collectively termed Part 3.X) is contained in the relevant Part, and it is not necessary to refer to AS/NZS 4755.1. All the information required to manufacture a Demand Response Enabling Device (DRED) which complies with AS/NZS 4755.1 is contained in this document, and it is not necessary to refer to AS/NZS 4755.3.X. However, remote agents and other prospective users and managers of the demand response framework described in Section 2 of this document should familiarize themselves with all Parts of AS/NZS 4755.

AS/NZS 4755.1 does not cover all aspects of construction and performance of the Demand Response Enable Device (DRED), which may be subject to other Standards.

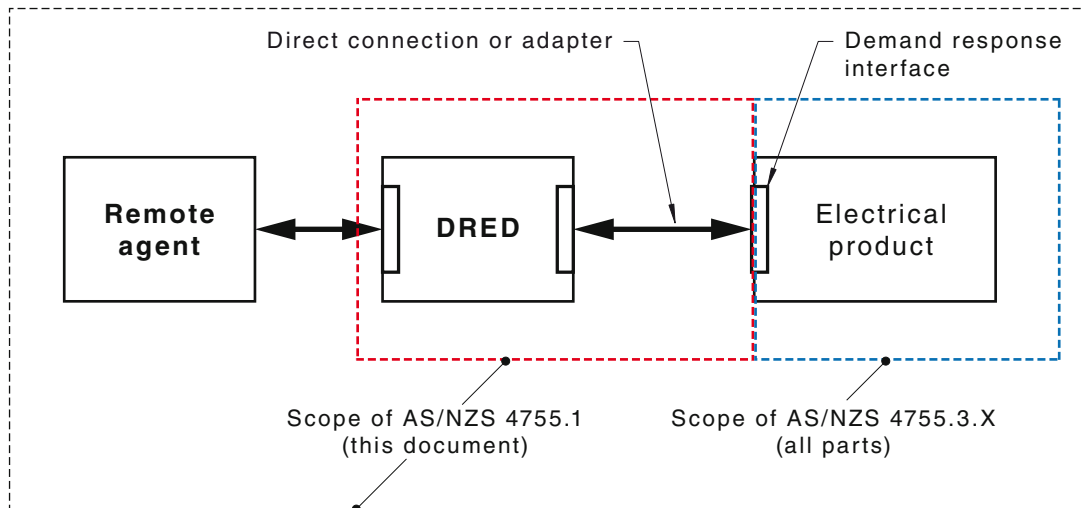

COVERAGE OF PARTS OF AS/NZS 4755

This Standard—

- (a) creates a framework that will allow off-the-shelf equipment, communications technologies and electrical products to be integrated and adapted so that demand management solutions may be developed and deployed in a timely and economical fashion;
- (b) specifies the minimum functionality of a DRED;
- (c) describes additional, optional functionalities which may be incorporated into a DRED; and
- (d) describes various means of communicating with a remote agent which enables DREDS to be designated as distinct classes. For example, a DRED meeting the requirements of Appendix B of this Standard is designated a Class B DRED, and a DRED meeting the requirements of Appendix C is designated a Class C DRED. The appendices are normative for DREDS which are designated as belonging to a specific class. Further appendices, which would create additional classes of DREDS may be added in future editions of this Standard.

A supplier who wishes to build a DRED that conforms to this Standard (AS/NZS 4755.1) but not with Appendix B or C may do so. However, the supplier would have to be able to demonstrate the ability of the DRED to receive commands from a remote agent via the communications channel(s) of which it is claimed to be capable.

The terms ‘normative’ and ‘informative’ are used in a Standard to define the application of the appendices or annexes to which they apply. A ‘normative’ appendix or annex is an integral part of a Standard, whereas an ‘informative’ appendix or annex is only for information and guidance.

CONTENTS

	<i>Page</i>
SECTION 1 SCOPE AND GENERAL	
1.1 SCOPE.....	5
1.2 REFERENCED DOCUMENTS.....	6
1.3 DEFINITIONS.....	6
SECTION 2 DEMAND RESPONSE FRAMEWORK	
2.1 GENERAL.....	10
2.2 DEMAND RESPONSE SYSTEM.....	10
SECTION 3 MINIMUM REQUIREMENTS OF A DRED	
3.1 GENERAL.....	11
3.2 MINIMUM CAPABILITIES AND REQUIREMENTS.....	11
3.3 COMMANDS AND OPERATIONAL INSTRUCTIONS	12
3.4 PHYSICAL AND ELECTRICAL REQUIREMENTS.....	13
SECTION 4 OPTIONAL CAPABILITIES OF A DRED	
4.1 GENERAL.....	17
4.2 RECORDING CONNECTED ELECTRICAL PRODUCTS.....	17
4.3 TWO-WAY COMMUNICATIONS	17
4.4 STANDARD DIMENSIONAL CONSTRAINTS.....	17
SECTION 5 LABELLING AND MARKING	
5.1 GENERAL.....	19
5.2 REGISTRATION	19
5.3 POINT OF SALE LABELLING.....	19
5.4 MARKING	19
5.5 DOCUMENTATION.....	19
SECTION 6 TESTING AND VERIFICATION	
6.1 GENERAL.....	20
6.2 SET-UP FOR TESTING.....	20
6.3 TESTING AND COMPLIANCE REPORT	20
APPENDICES	
A STATEMENTS OF COMPLIANCE AND TEST REPORTS.....	21
B CLASS B DRED (ZIGBEE SEP 1.1.X ENABLED).....	25
C CLASS C DRED (RIPPLE CONTROL ENABLED).....	29
D EXAMPLE OF CIRCUIT WITH SIX PIN CONNECTIONS	30

STANDARDS AUSTRALIA/STANDARDS NEW ZEALAND

Australian/New Zealand Standard**Demand response capabilities and supporting technologies for electrical products****Part 1: Demand response framework and requirements for demand response enabling devices (DREDS)**

SECTION 1 SCOPE AND GENERAL

1.1 SCOPE

This Standard specifies a demand response framework, which consists of a DRED complying with AS/NZS 4755.1 and one or more electrical products complying with the relevant parts of AS/NZS 4755.3.

This Standard also specifies the following:

- (a) Minimum physical requirements for a DRED.
- (b) Minimum levels of functionality for a DRED.
- (c) Optional capabilities and functionalities.
- (d) Various means of communicating with a remote agent which allow a DRED to be designated as a specific class.

NOTE: For example, a DRED that complies with the means of communication specified in Appendix B is designated a Class B DRED, and a DRED that complies with the means of communication specified in Appendix C is designated a Class C DRED.

- (e) Means of connecting a DRED to the demand response interface(s) on one or more electrical products meeting the requirements of AS/NZS 4755.3.X.

NOTE: AS/NZS 4755.3.1, AS/NZS 4755.3.2, AS/NZS 4755.3.3, AS/NZS 4755.3.4 and AS/NZS 4755.3.5 are collectively called AS/NZS 4755.3.X in this document.

- (f) Labelling and marking requirements for a DRED.

The Standard sets out an approach to the verification and testing of DRED capabilities.

This Standard does not—

- (i) cover products with functions similar to those of DREDS that may interact with or control the operation of categories of electrical products not covered by AS/NZS 4755.3.X;
- (ii) specify or limit the means of communication between the remote agent and the DRED (other than DREDS of a class covered by an appendix);
- (iii) specify or limit the form of connection or communication between parts of multi-part DREDS; or
- (iv) limit additional capabilities that the DRED may have beyond those specified, provided such capabilities do not conflict with the requirements of this Standard.

Other statutory or regulatory requirements may be applicable to the product(s) that fall within the scope of this Standard. It is the manufacturer's, importer's or distributor's responsibility (as appropriate) to ensure that products comply with such requirements.