

Australian/New Zealand Standard™

**Demand response capabilities and
supporting technologies for electrical
products**

**Part 3.1: Interaction of demand
response enabling devices and
electrical products—Operational
instructions and connections for air
conditioners**



AS/NZS 4755.3.1:2012

This Joint Australian/New Zealand Standard was prepared by Joint Technical Committee EL-054, Remote Demand Management of Electrical Products. It was approved on behalf of the Council of Standards Australia on 19 April 2012 and on behalf of the Council of Standards New Zealand on 26 April 2012.

This Standard was published on 17 May 2012.

The following are represented on Committee EL-054:

Air Conditioning and Refrigeration Equipment Manufacturers Association of Australia
Australian Industry Group
Australian Institute of Refrigeration, Air conditioning and Heating
Consumer Electronics Suppliers Association
Consumers' Federation of Australia
Copper Development Centre Australia
CSIRO Energy Technology
Department of Climate Change and Energy Efficiency
Department of Resources, Energy and Tourism
Electricity Engineers' Association of New Zealand
Electricity Networks Association of New Zealand
Energy Networks Association
Energy Users Association of Australia
Refrigeration and Air Conditioning Association of New Zealand
Swimming Pool and Spa Association of Australia

Keeping Standards up-to-date

Standards are living documents which reflect progress in science, technology and systems. To maintain their currency, all Standards are periodically reviewed, and new editions are published. Between editions, amendments may be issued. Standards may also be withdrawn. It is important that readers assure themselves they are using a current Standard, which should include any amendments which may have been published since the Standard was purchased.

Detailed information about joint Australian/New Zealand Standards can be found by visiting the Standards Web Shop at www.saiglobal.com.au or Standards New Zealand web site at www.standards.co.nz and looking up the relevant Standard in the on-line catalogue.

For more frequent listings or notification of revisions, amendments and withdrawals, Standards Australia and Standards New Zealand offer a number of update options. For information about these services, users should contact their respective national Standards organization.

We also welcome suggestions for improvement in our Standards, and especially encourage readers to notify us immediately of any apparent inaccuracies or ambiguities. Please address your comments to the Chief Executive of either Standards Australia or Standards New Zealand at the address shown on the back cover.

This Standard was issued in draft form for comment as DR AS/NZS 4755.3.1.

Australian/New Zealand Standard™

Demand response capabilities and supporting technologies for electrical products

Part 3.1: Interaction of demand response enabling devices and electrical products—Operational instructions and connections for air conditioners

Originated as AS 4755.3.1—2008.
Second edition 2012.

COPYRIGHT

© Standards Australia Limited/Standards New Zealand

All rights are reserved. No part of this work may be reproduced or copied in any form or by any means, electronic or mechanical, including photocopying, without the written permission of the publisher, unless otherwise permitted under the Copyright Act 1968 (Australia) or the Copyright Act 1994 (New Zealand).

Jointly published by SAI Global Limited under licence from Standards Australia Limited, GPO Box 476, Sydney, NSW 2001 and by Standards New Zealand, Private Bag 2439, Wellington 6140

PREFACE

This Standard was prepared by the Joint Standards Australia/Standards New Zealand Committee EL-054, Remote Demand Management of Electrical Products, to supersede AS 4755.3.1—2008.

This Standard forms part of a series of Standards that is intended to define the nomenclature, architecture and operational instructions for systems that can be used to remotely control electrical products. AS 4755—2007 will be revised and re-designated to become AS/NZS 4755.1. When complete, the series will comprise the following:

AS/NZS

- 4755 Demand response capabilities and supporting technologies for electrical products
- 4755.1 Part 1: Framework for demand response capabilities and requirements for demand response enabling devices (DREDS)
 - 4755.3.1 Part 3.1: Interaction of demand response enabling devices and electrical products—Operational instructions and connections for air conditioners (this Standard)
 - 4755.3.2 Part 3.2: Interaction of demand response enabling devices and electrical products—Operational instructions and connections for devices controlling swimming pool pump-units
 - 4755.3.3 Part 3.3: Interaction of demand response enabling devices and electrical products—Operational instructions and connections for electric and electric-boosted water heaters
 - 4755.3.4 Part 3.4: Interaction of demand response enabling devices and electrical products—Operational instructions and connections for charge/discharge controllers for electric vehicles and other energy storage devices
 - 4755.3.5 Part 3.5: Interaction of demand response enabling devices and electrical products—Operational instructions and connections for inverters and controllers for photovoltaic and other small-scale generators

The figure below depicts the structure of the AS/NZS 4755 series. This Standard (AS/NZS 4755.3.1) covers the interaction of air conditioners with demand response enabling devices (DREDS).

This Standard does not cover all aspects of construction and performance, which may be subject to other standards.

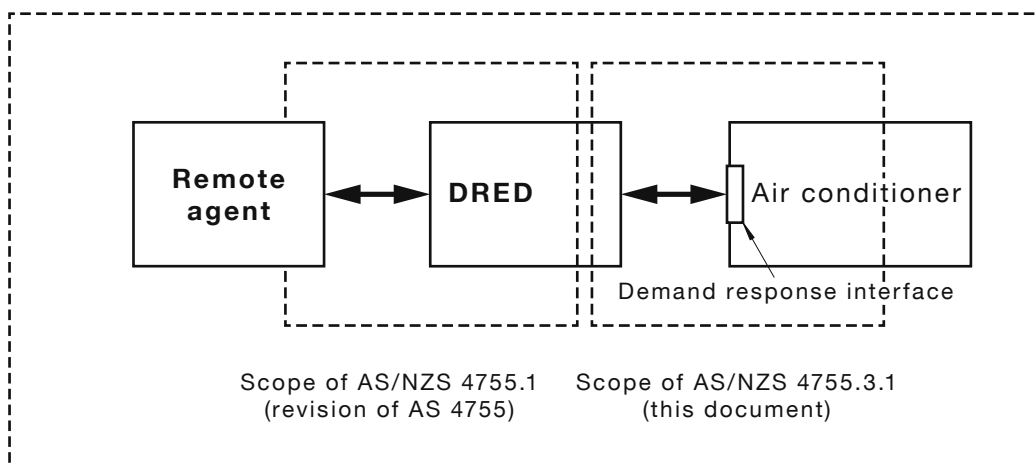

It is recommended that this Standard be read in conjunction with AS/NZS 4755.1.

The AS/NZS 4755 series creates a framework that will allow off-the-shelf equipment, communications technologies and electrical products to be integrated and adapted so that demand management solutions may be developed and deployed in a timely and economical fashion.

Although the series has been developed to support situations where demand response is initiated or managed by a remote agent, with the consent of the owner or user of the electrical product, there is no technical reason that prevents the owner or user taking direct responsibility for demand response, by managing the DRED independently of any remote agent, provided the DRED meets the requirements of AS/NZS 4755.1.

This Standard pertains to a particular electrical product, the air conditioner. The Standard—

- (a) specifies the standard demand response interface on an air conditioner; and
- (b) specifies a standard set of operational instructions for that air conditioner.

Detailed standards covering demand response operational instructions and interfaces with DREDs for other electrical products may also be prepared as needs are identified.

This Standard is intended to support demand response programs that optimize the operation of the electricity supply system and allow the efficient planning and use of capital equipment, while minimizing the risks to the comfort and amenity of air conditioner users.

The costs and benefits of making this Standard mandatory are the subject of consideration by Australian and New Zealand Governments. If compliance were mandated, it would also be mandatory to register product details with the regulators of the national energy labelling and minimum energy performance standards program. Information about the status of this Standard and registration procedures (if required) is available at www.energyrating.gov.au.

Statements expressed in mandatory terms in notes to tables are deemed to be requirements of this Standard.

The term ‘normative’ has been used in this Standard to define the application of the appendix to which it applies. A ‘normative’ appendix is an integral part of a Standard.

CONTENTS

	<i>Page</i>
SECTION 1 SCOPE AND GENERAL	
1.1 SCOPE.....	5
1.2 REFERENCED DOCUMENTS.....	5
1.3 DEFINITIONS.....	6
SECTION 2 OPERATIONAL INSTRUCTIONS AND DEMAND RESPONSE MODES	
2.1 GENERAL PRINCIPLES.....	9
2.2 DEMAND RESPONSE MODES.....	9
2.3 OVERRIDE CAPABILITY.....	11
2.4 RESPONSE TIMES.....	11
2.5 OPERATION OF AUXILIARY EQUIPMENT.....	11
2.6 HEATING AND COOLING MODES.....	12
2.7 OVER-CAPACITY OPERATION.....	12
SECTION 3 INTERFACES	
3.1 GENERAL.....	13
3.2 PHYSICAL INTERFACES.....	13
3.3 TERMINAL BLOCK.....	13
3.4 RJ45 SOCKET.....	14
3.5 CIRCUIT TO DRED.....	15
3.6 OPTIONAL ELECTRICAL SUPPLY.....	16
3.7 LOCATION AND ACCESS.....	16
SECTION 4 LABELLING AND MARKING OF DEMAND RESPONSE CAPABILITY	
4.1 GENERAL.....	17
4.2 REGISTRATION.....	17
4.3 POINT OF SALE LABELLING.....	17
4.4 MARKING.....	17
4.5 MANUFACTURER'S LITERATURE.....	18
SECTION 5 TESTING AND VERIFYING DEMAND RESPONSE CAPABILITY	
5.1 VERIFICATION OF CLAIMED DEMAND RESPONSE CAPABILITY.....	19
5.2 SET-UP FOR TESTING.....	20
5.3 VERIFICATION OF CLAIMED COMPLIANCE WITH DRM 1.....	20
5.4 VERIFICATION OF CLAIMED COMPLIANCE WITH DRM 2.....	21
5.5 VERIFICATION OF CLAIMED COMPLIANCE WITH DRM 3.....	23
5.6 TEST REPORT.....	24
APPENDICES	
A VERIFICATION OF CLAIMED DEMAND RESPONSE CAPABILITY FOR AIR CONDITIONERS.....	25

STANDARDS AUSTRALIA/STANDARDS NEW ZEALAND

Australian/New Zealand Standard**Demand response capabilities and supporting technologies for electrical products****Part 3.1: Interaction of demand response enabling devices and electrical products—Operational instructions and connections for air conditioners**

SECTION 1 SCOPE AND GENERAL

1.1 SCOPE

This Standard defines a set of operational instructions that will meet the requirements of remote agents wishing to control the energy consumption and operation of air conditioners and establishes a consistent approach to the method of connecting the demand response interface to the demand response enabling device (DRED).

Air conditioners covered by this Standard include, but are not restricted to, single-phase and three-phase air conditioners of the vapour compression type that fall within the scope of the AS/NZS 3823 series.

NOTE: If compliance with this Standard is made mandatory by the relevant Australian and New Zealand regulatory authorities then any exclusions of product types, limitations on cooling output or other criteria for limiting regulatory scope will be included in AS/NZS 3823.2. In the event of any such regulatory limitations, this Standard can still be used voluntarily for any product within the scope of the AS/NZS 3823 series. (It is understood that a new part of AS/NZS 3823, to cover multi-split systems, is near completion).

1.2 REFERENCED DOCUMENTS

The following documents are referred to in this Standard:

AS

4755* Framework for demand response capabilities and supporting technologies for electrical products

62052.21 Electricity metering equipment (ac)—General requirements, tests and test conditions—Tariff and load control equipment (IEC 62052-21, Ed. 1.0 (2004) MOD)

AS/NZS

3000 Electrical installations (known as the Australian/New Zealand Wiring Rules)

3823 Performance of electrical appliances—Air conditioners and heat pumps (series)

3823.2 Part 2: Energy labelling and minimum energy performance standard (MEPS) requirements

4755 Demand response capabilities and supporting technologies for electrical products (series)

4755.1* Part 1: Framework for demand response capabilities and requirements for demand response enabling devices

4755.3.1 Part 3.1: Interaction of demand response enabling devices and electrical products—Operational instructions and connections for air conditioners (this Standard)