

Dup.
SUPERSEDED BY: AS 2766-1997

*Amendment 1 - July 1985
Amendment 2 - June, 1986.*

AS 2766—1985
UDC 542.231.5-036.5

Australian Standard[®] 2766—1985

PETRI DISHES— PLASTICS—FOR SINGLE USE



STANDARDS ASSOCIATION OF AUSTRALIA
Incorporated by Royal Charter



This Australian standard was prepared by Committee CH/1, Laboratory Glassware and Related Apparatus. It was approved on behalf of the Council of the Standards Association of Australia on 7 November 1984 and published on 4 March 1985.

The following interests are represented on Committee CH/1:

Commonwealth Scientific and Industrial Research Organization
Confederation of Australian Industry
Department of Agriculture, N.S.W.
Department of Health (Commonwealth)
Department of Science and Technology
Government Chemical Laboratories, W.A.
National Standards Commission
Railways of Australia Committee
Royal Australian Chemical Institute
University of Sydney

Representatives of the following interests also participated in the drafting of this standard:

Australian Diagnostics Corporation Pty Ltd
Australian Institute of Medical Laboratory Scientists
Australian Medical Association
Filtrona Bunzl
Medical Plastics Pty Ltd
National Biological Standards Laboratory
Royal College of Pathologists of Australia
Sterilope Health Care Products

Review of Australian Standards. To keep abreast of progress in industry, Australian standards are subject to periodic review and are kept up-to-date by the issue of amendments or new editions as necessary. It is important therefore that standards users ensure that they are in possession of the latest edition, and any amendments thereto.

Full details of all SAA publications will be found in the Catalogue of SAA Publications; this information is supplemented each month by SAA's journal 'The Australian Standard', which subscribing members receive, and which gives details of new publications, new editions and amendments, and of withdrawn standards.

Suggestions for improvements to Australian standards, addressed to the head office of the Association, are welcomed. Notification of any inaccuracy or ambiguity found in an Australian standard should be made without delay in order that the matter may be investigated and appropriate action taken.

This standard was issued in draft form for comment as DR 80250.

This standard was issued in draft form for comment as DR 80250.

STANDARDS ASSOCIATION OF AUSTRALIA
Incorporated by Royal Charter

AMENDMENT No 2
to
AS 2766—1985
PETRI DISHES—PLASTICS—FOR SINGLE USE

REVISED TEXT

SUMMARY: This amendment applies to Table 1 and Clause 7.5. It supersedes AMENDMENT No 1 of July 1985.

Published on 2 June 1986.

AMDT
No 2
JUNE
1986

Page 4, Table 1.

Replace Table 1 with the following table.

TABLE 1
DIMENSIONS AND TOLERANCES FOR PLASTICS PETRI DISHES

Item	Dimension under consideration (see Fig. 1)	Dimension mm	Tolerance mm
Overall Petri dish	Nominal diameter (d_o)	90	—
	Difference between external height of lid and the total height of the assembled dish (Δh)	3.0 (minimum)	—
	Lateral clearance between internal wall of lid and external wall of base ($d_L - d_B$)	$1.0 \leq (d_L - d_B) \leq 2.0$	—
Lid	External height (h_L)	8.5	± 1.5
	Internal diameter (d_L), measured between sidewalls	90.5	± 2.0
Base	External height (h_B), excluding stacking rim	14.0	± 2.0
	External diameter (d_B)	89.0	± 1.5

AMDT
No 2
JUNE
1986

Page 4. After Clause 7.4.

Insert the following new clause:

7.5 Lateral clearance ($d_L - d_B$). Notwithstanding the dimension given in Table 1, the dimensions of the lid and the base shall be such that the lateral clearance between lid and base, ($d_L - d_B$) shall be not less than 1.0 mm or greater than 2.0 mm.

STANDARDS ASSOCIATION OF AUSTRALIA
Incorporated by Royal Charter

AMENDMENT No 1
to
AS 2766—1985
PETRI DISHES—PLASTICS—FOR SINGLE USE

CORRECTION

SUMMARY: This amendment applies to Table 1.

Published on 12 July 1985.

Page 4. Table 1. Column 'Dimension under consideration (see Fig. 1)'
Second item—Lid—(line 2)—the words 'Internal height (h_L)' should read 'Internal
diameter (d_L)'. AMDT
No 1
July
1985

X

AUSTRALIAN STANDARD

**PETRI DISHES—
PLASTICS—FOR SINGLE USE**

AS 2766—1985

First published.....1985

**PUBLISHED BY THE STANDARDS ASSOCIATION OF AUSTRALIA
STANDARDS HOUSE, 80 ARTHUR ST, NORTH SYDNEY, N.S.W.**

ISBN 0 7262 3620 9



8 MAR 1985

PREFACE

This standard was prepared by the Association's Committee on Laboratory Glassware and Related Apparatus under the direction of the Chemical Standards Board.

Probably the most critical specifications are those dealing with the various sterility aspects of the dishes. After considerable debate and investigations, the Committee has found it necessary to refer any such matters to the National Biological Standards Laboratory NBSL which is the established authority for inspecting and assessing the suitability of the process of sterilizing or of sterile manufacture of dishes to meet the medically accepted criteria in Australia.

Further highlights of the standard include the confirmatory tests (Appendices A to G) for checking specifications which do not require any sophisticated equipment or expertise and can be done rapidly. For example, the test probe utilized in the rigidity/deformation tests can be of any dimension provided that the tip dimensions are met, and this conforms to that already in common use in the testing of electrical appliance housings.

Glass Petri dishes are covered in AS 2379, Laboratory Glassware—Glass Petri Dishes.

CONTENTS

	<i>Page</i>
1 SCOPE	3
2 REFERENCED DOCUMENTS	3
3 DEFINITIONS	3
4 DESIGN	3
5 MATERIAL	4
6 CONSTRUCTION	4
7 DIMENSIONAL REQUIREMENTS	4
8 PHYSICAL REQUIREMENTS	4
9 FREEDOM FROM CONTAMINANTS	5
10 SELECTION OF SPECIMENS FOR TESTING	5
11 PACKAGING	5
12 IDENTIFICATION AND MARKING	5
 APPENDICES	
A Method for Determination of the Microbiological Inertness of a Plastics Petri Dish	6
B Method for Determination of Flatness of a Petri Dish	8
C Method for Determination of Rigidity of a Plastics Petri Dish	10
D Method for Determination of the Resistance to Permanent Deformation	12
E Method for Determination of the Stability in Stacking	14
F Method for Determination of the Resistance to Thermal Distortion	14
G Method for Determination of the Resistance to Rupture of a Sealed Package of Petri Dishes when Subjected to Mechanical Shock	15
H Determination of Compliance of a Lot	16

©Copyright — STANDARDS ASSOCIATION OF AUSTRALIA 1985

Users of standards are reminded that copyright subsists in all SAA publications. No part of this publication may be reproduced, stored in a retrieval system in any form or transmitted by any means without prior permission in writing of the Standards Association of Australia.

STANDARDS ASSOCIATION OF AUSTRALIA

Australian Standard

for

PETRI DISHES—PLASTICS—FOR SINGLE USE

1 SCOPE. This standard specifies requirements for plastics Petri dishes intended for single use in microbiological testing.

2 REFERENCED DOCUMENTS. The following standards are referred to in this standard:

AS 1199	Sampling Procedures and Tables for Inspection by Attributes
AS 1399	Guide to AS 1199, Sampling Procedures and Tables for Inspection by Attributes
AS 1821-23	Suppliers' Quality Control Systems—Levels 1, 2 and 3
AS 2000	Guide to AS 1821-1823, Suppliers Quality Control Systems
AS 2490	Sampling Procedures and Charts for Inspection by Variables for Percent Defective

3 DEFINITIONS. For the purpose of this standard, the following definitions apply (see also Fig. 1):

3.1 Base—the component of the Petri dish with the lesser diameter.

3.2 Lid—the component of the Petri dish with the greater diameter.

3.3 Petri dish—the complete article comprising both lid and base.

3.4 Stacking rim—protrusion(s) on the outside edge of the base of the dish. It is/they are designed to prevent direct contact between the flat outside face of the base and the surface on which it rests.

4 DESIGN.

4.1 General. The Petri dishes described herein shall be of a circular shape and may be manufactured with separate compartments. The base of each dish shall be fitted with a stacking rim. Unless otherwise specified, ventilation of the interior of the closed dish shall be provided by fitting at least three (3) ridges to the top of the inside of the lid, such that when the lid is placed on the base, only the ridges shall rest on the rim of the base thereby facilitating gas movement into and out of the dish.

The cross-sectional design of the components shall be similar to that illustrated in Fig. 1.

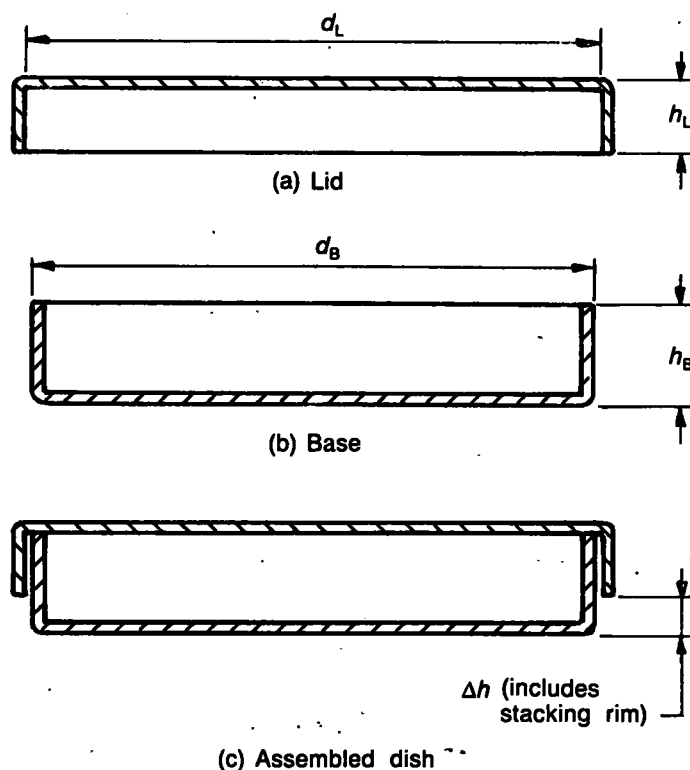

Fig. 1. DIAGRAMMATIC REPRESENTATION OF A PLASTICS PETRI DISH EXCLUDING THE STACKING RIM