

AS 1100 Pt 201 1984

AS 1100, Part 12—1979  
UDC 744.4

# Australian Standard 1100, Part 12—1979

*Cover*

*binding June 1980*

## DRAWING PRACTICE CONVENTIONAL REPRESENTATIONS

STANDARDS ASSOCIATION  
OF AUSTRALIA  
- 6 JUN 1979  
MELBOURNE LIBRARY

**PUBLISHED BY THE STANDARDS ASSOCIATION OF AUSTRALIA  
STANDARDS HOUSE, 80 ARTHUR ST, NORTH SYDNEY, N.S.W.**

*Incorporated by Royal Charter*



THE FOLLOWING SCIENTIFIC, INDUSTRIAL, AND GOVERNMENTAL DEPARTMENTS and organizations were officially represented on the committee entrusted with the preparation of this standard:

Association for Computer Aided Design Ltd  
Association of Consulting Engineers Australia  
Australian Gas Association  
Bureau of Steel Manufacturers of Australia  
Confederation of Australian Industry  
CSIRO, National Measurement Laboratory  
Department of Construction  
Department of Defence  
Department of Productivity  
Design and Drafting Contractors Association  
Electricity Supply Association of Australia  
Institute of Draftsmen, Australia  
Institution of Engineers, Australia  
Institution of Production Engineers  
Masters Builders Federation of Australia Inc.  
Postmaster-General's Department  
Royal Australian Institute of Architects  
Society of Automotive Engineers—Australasia  
Telecom Australia  
Universities

---

This standard, prepared by Committee MS/32, Technical Drawing, was approved on behalf of the Council of the Standards Association of Australia on 26 February 1979, and was published on 1 June 1979.

To keep abreast of progress in industry, Australian standards are regularly reviewed. Suggestions for improvements to published standards, addressed to the head office of the Association, are welcomed.

First published ..... 1979
----------------------------

*This standard was issued in draft form for public review as DR 76002.*

ISBN 0 7262 1657 7

June 1980

**STANDARDS ASSOCIATION OF AUSTRALIA**

Incorporated by Royal Charter

---

**CORRIGENDUM**

to

**AS 1100, Part 12—1979**

**DRAWING PRACTICE—CONVENTIONAL REPRESENTATIONS**

**SUMMARY:** This correction slip applies to Corrigenda March 1980.

Published on 1 July 1980.

---

---

**Corrigenda (March 1980).**

**Table 2.3—*delete* correction to this table (i.e. restore the table to its original condition).**

---

**CORRIGENDA**  
to  
**AS 1100, Part 12—1979**  
**DRAWING PRACTICE—CONVENTIONAL REPRESENTATIONS**

*SUMMARY:* This correction slip applies to Tables 2.2, 2.3, 2.6 and 2.8.

Published on 1 April 1980.

**Page 6. Table 2.2.**

**Column 3 HOLE (SECTIONED) and HOLE (HIDDEN)—*delete existing diagrams and substitute:***

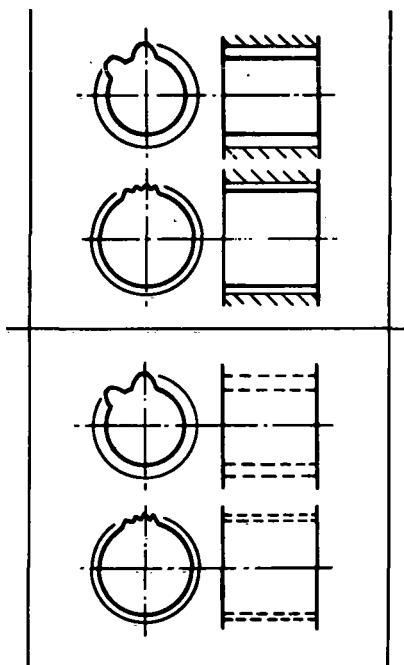

**Page 7. Table 2.3.**

*Transpose the drawings in columns 2 and 3 thus:*

*As original  
(copy)*

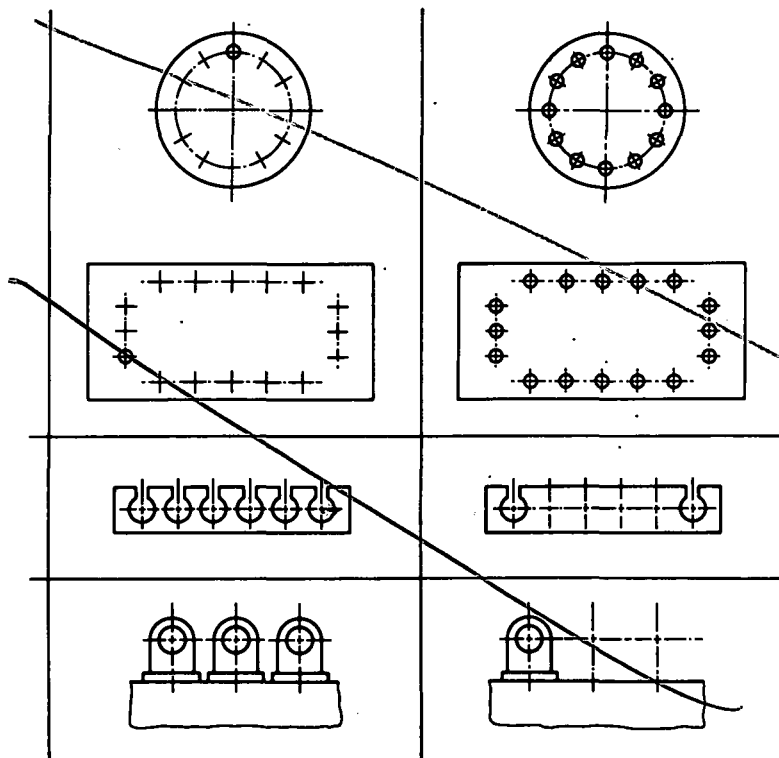

Insert numeral '3' at top of column 3.

Columns 2 and 3, THREADED PART and THREAD INSERTS—delete existing diagrams and substitute:

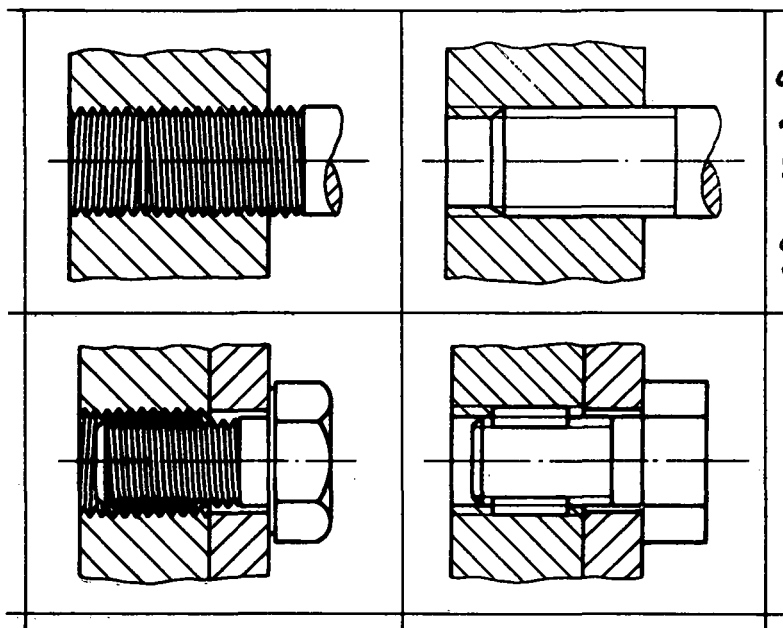

Note:  
thickness of  
lines were meant  
to be altered.  
But printing  
error made  
this copy  
thicker instead  
of thinner.  
Withdrawal  
of this copy  
intended.

Columns 2 and 3, LEAF (SPRINGS), Semi-elliptic and Semi-elliptic with eyelets—transpose the diagrams thus:

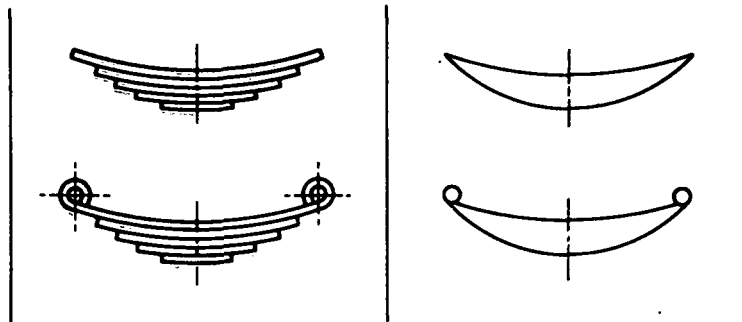

## PREFACE

This standard was prepared by the Association's Committee on Technical Drawings.

Conventional representation of various features and parts has always been an essential ingredient of drafting practice and has received considerable attention from various technical committees of the International Organization for Standardization (ISO). The work of these ISO technical committees and of other national standards bodies has been studied in the compilation of examples for this standard.

Because ISO TC 10/SC 6, Technical Drawings—Particular Representation in Technical Drawings, is considering a number of projects, the SAA committee decided that provision be made in the layout of this standard for the insertion of the results of these

projects. Representation of seals is one subject of this nature.

Acknowledgement is made of the assistance obtained from the following documents:

ISO/R 128	Engineering Drawings—Principles of Presentation
ISO 2162	Technical Drawings—Representation of Springs
ISO 2203	Technical Drawings—Conventional Representation of Gears
BS 308	Engineering Drawing Practice

The decimal marker used in this document is the dot on the line. Inconsistency with other Parts of AS 1100 will disappear as these Parts are revised.

## CONTENTS

	<i>Page</i>		<i>Page</i>
<b>SECTION 1. SCOPE AND GENERAL</b>		2.2 Splines and Serrations ....	6
1.1 Scope ....	4	2.3 Repeated Features and Parts ....	7
1.2 Application ....	4	2.4 Screw Threads ....	7
1.3 Method of Presentation ....	4	2.5 Threaded Fasteners ....	9
1.4 Types of Lines ....	4	2.6 Threaded Assemblies ....	13
<b>SECTION 2. REPRESENTATION OF FEATURES AND PARTS</b>		2.7 Riveted Assemblies ....	14
2.1 Knurling ....	5	2.8 Springs ....	14
		2.9 Gears....	19
		2.10 Ball and Roller Bearings ....	23

©Copyright — STANDARDS ASSOCIATION OF AUSTRALIA 1979

Users of standards are reminded that copyright subsists in all SAA publications. No part of this publication may be reproduced, stored in a retrieval system in any form or transmitted by any means without prior permission in writing of the Standards Association of Australia.

## STANDARDS ASSOCIATION OF AUSTRALIA

---

**Australian Standard**  
**for**  
**DRAWING PRACTICE**

---

**PART 12—CONVENTIONAL REPRESENTATIONS**

---

**SECTION 1. SCOPE AND GENERAL**

**1.1 SCOPE.** This standard specifies conventions for the representation of components and repetitive features of components. These conventions are simplified drafting techniques for depicting a component or repetitive feature to obviate unnecessary detailing.

**1.2 APPLICATION.** Section 2 describes the conventional representation of a part, repetition of features in a part, or repetition of parts in an assembly. General details and guidelines are given in the text of each clause and examples are shown in a table following the text.

The tables consist of four columns as follows:

- (a) *Column 1—Description.* Taken in conjunction with the title of the table this column gives a broad statement of the feature or component to which the conventional representation applies.
- (b) *Column 2—Drawing of feature or component.* This column illustrates by way of an example a feature or component drawn according to the methods detailed in other Parts of AS 1100.
- (c) *Column 3—Conventional representation.* The drawing in this column is an example of the

conventional representation of the feature or component.

- (d) *Column 4—Requirements and remarks.* The information in this column gives further requirements and remarks that apply to the particular example illustrated.

**1.3 METHOD OF PRESENTATION.** A conventional representation may be either a simplified drawing of the feature being depicted or a symbol for the feature being depicted, e.g. a cross representing a rivet (see Clause 2.7).

Where the conventional representation is a simplified drawing, it is drawn to scale. Dimensions and other details may be applied directly to this drawing or by means of tabulated data or other suitable methods.

Where the conventional representation is a symbol, there is no relationship between the size of the symbol and the size of the feature it depicts.

**1.4 TYPES OF LINES.** Types of lines specified in this standard are detailed in AS 1100, Part 5.