

2393

~~REFERENCE COPY  
INFORMATION CENTRE  
STANDARDS AUSTRALIA~~

AS 2393—1980  
UDC 631.372:629.1.013

# Australian Standard 2393—1980

---

WITHDRAWN:  
19990701

## HYDRAULIC COUPLER FOR AGRICULTURAL TRACTORS



**STANDARDS ASSOCIATION OF AUSTRALIA**  
*Incorporated by Royal Charter*



THE FOLLOWING SCIENTIFIC, INDUSTRIAL AND GOVERNMENTAL ORGANIZATIONS and departments were officially represented on the committee entrusted with the preparation of this standard:

Agricultural Equipment Committee  
Australian Workers Union  
CSIRO, Division of Mechanical Engineering  
Department of Agriculture, N.S.W.  
Department of Agriculture, Victoria  
Department of Industrial Relations, N.S.W.  
Department of Labour and Industry, Victoria  
Department of Labour Relations, Qld  
Department of Primary Industries, Qld  
National Farmers Federation  
National Safety Council of Australia (Victoria Division)  
Queensland Agricultural College  
Queensland Cane Growers Council  
Safety Institute of Australia  
Tractor and Machinery Association of Australia  
University of New South Wales

---

This standard, prepared by Committee AG/4, Agricultural Tractors and Machinery, was approved on behalf of the Council of the Standards Association of Australia on 18 August 1980, and was published on 1 November 1980.

To keep abreast of progress in industry, Australian standards are subject to continuous review and are kept up-to-date by the issue of amendments or new editions as necessary. It is important therefore that standards users ensure that their standards are up-to-date. Full details of all SAA publications will be found in the Annual List of Australian Standards; these details are supplemented by listings in the SAA monthly journal 'The Australian Standard'. Information on the Annual List and 'The Australian Standard' may be obtained from any sales office of the Association, where details are also available of the current status of individual standards. Suggestions for improvements to published standards, addressed to the head office of the Association, are welcomed.

---

*This standard was issued in draft form for public review as DR 79142.*

**AUSTRALIAN STANDARD**

# **HYDRAULIC COUPLER FOR AGRICULTURAL TRACTORS**

**AS 2393—1980**

First published .....1980

**PUBLISHED BY THE STANDARDS ASSOCIATION OF AUSTRALIA  
STANDARDS HOUSE, 80 ARTHUR ST, NORTH SYDNEY, N.S.W.**

ISBN 0 7262 2036 1



## PREFACE

This standard was prepared by the Association's Committee on Agricultural Tractors and Machinery at the request of primary producers.

The standard is based on, and is technically equivalent to, Draft International Standard ISO/DIS 5675 prepared by ISO Technical Committee ISO/TC 23—Tractors and Machinery for Agriculture and Forestry, except for the specified valve protrusion (dimension  $L_s$ ). In ISO/DIS 5675 the valve protrusion (and thus valve travel) is specified as a *minimum* dimension for both the male part and the female part. In this standard, the valve protrusion dimension for the male part is specified as a *maximum* dimension to allow the female part to be designed so that the coupler may be connected with pressure in the male part.

With minor variations, the coupler is equivalent to one size (12.5 mm) from the European Oil Hydraulic and Pneumatic Committee (CETOP) range of quick disconnect couplings and to the coupler specified in the American Society of Agricultural Engineers Standard ASAE S366.

Until recently, the coupler covered by this standard was adequate for the needs of most agricultural machinery. However, with the development of larger tractors and agricultural machines, couplers with higher flow capacity and/or pressure rating are required now. In an attempt to forestall the emergence of a multiplicity of non-interchangeable couplers, the committee will propose to ISO/TC 23 that a new work item be added to their program for a standard for couplers larger than that covered in ISO/DIS 5675.

©Copyright — STANDARDS ASSOCIATION OF AUSTRALIA 1980

Users of standards are reminded that copyright subsists in all SAA publications. No part of this publication may be reproduced, stored in a retrieval system in any form or transmitted by any means without prior permission in writing of the Standards Association of Australia.

STANDARDS ASSOCIATION OF AUSTRALIA

Australian Standard

for

HYDRAULIC COUPLER FOR AGRICULTURAL TRACTORS

**1 SCOPE.** This standard specifies the essential interface dimensions, the installation dimensions and the operating requirements for an hydraulic coupler used to transmit hydraulic power from agricultural tractors to agricultural machinery. The clearance zone for the attachment of the coupler to the tractor is also given.

**2 APPLICATION.** This standard applies to couplers used on hydraulic lines which must be connected and disconnected frequently to allow the transfer of machinery from one tractor to another.

**3 DEFINITIONS.** For the purpose of this

standard, the following definitions apply:

**3.1 Shall and should**—shall is taken to be mandatory; should is taken to be advisory.

**3.2 Components of coupler.**

**3.2.1 Female part**—the part which incorporates a spring-loaded sleeve and locking balls, and is provided with a cavity to receive the male part.

**3.2.2 Male part**—the probe which fits and locks into the cavity in the female part.

**4 DIMENSIONAL CHARACTERISTICS:** The coupler shall comply with the dimensional characteristics specified in Fig. 1.

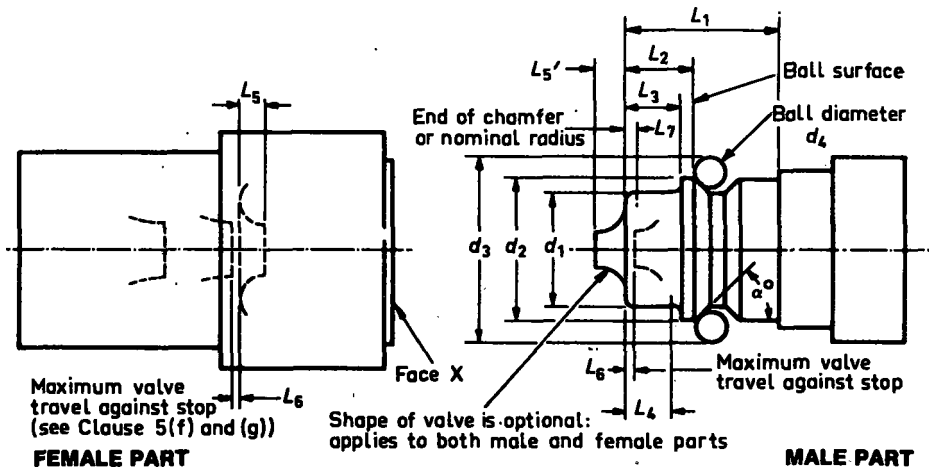

Detail	Size	Remarks
$d_1$ max. min.	20.56 20.48	$\text{⊙} \quad \phi \quad 0.025 \quad d_2$
$d_2$ max. min.	23.74 23.66	—
$d_3$	30.30	Gauge diameter (see note 2)
$d_4$	4.762	—
$L_1$ min.	24.00	—
$L_2$ max. min.	11.79 11.66	See note 2
$L_3$ max. min.	9.4 9.2	—
$L_4$ min.	8.50	Length of diameter $d_1$
$L_5$ min.	4.00	Valve protrusion (female part)
$L_5'$ max.	4.00	Valve protrusion (male part)
$L_6$	0.0-0.5	—
$L_7$ max.	1.5	—
$\alpha$ max. min.	46° 44°	—

**NOTES:**

- The configuration of the coupler shown is solely for the purpose of illustration and to give dimensional references. It is not intended to give design requirements.
- Dimension  $L_2$  applies when the ball diameter  $d_4$  is held at a gauge diameter of  $d_3$  and also against the flank of the ball groove nearest the nose of the valve.

DIMENSIONS IN MILLIMETRES

Fig. 1. HYDRAULIC COUPLER—DIMENSIONAL CHARACTERISTICS