

INTERNATIONAL STANDARD

NORME INTERNATIONALE

Connectors for electrical and electronic equipment – Product requirements – Part 3-123: Rectangular connectors – Detail specification for hybrid connectors for industrial environments, for power supply and fibre optic data transmission, with push-pull locking

Connecteurs pour équipements électriques et électroniques – Exigences de produit – Partie 3-123: Connecteurs rectangulaires – Spécification particulière relative aux connecteurs hybrides dans des environnements industriels pour l'alimentation et la transmission de données fibronique, avec verrouillage de type pousser-tirer



THIS PUBLICATION IS COPYRIGHT PROTECTED

Copyright © 2019 IEC, Geneva, Switzerland

All rights reserved. Unless otherwise specified, no part of this publication may be reproduced or utilized in any form or by any means, electronic or mechanical, including photocopying and microfilm, without permission in writing from either IEC or IEC's member National Committee in the country of the requester. If you have any questions about IEC copyright or have an enquiry about obtaining additional rights to this publication, please contact the address below or your local IEC member National Committee for further information.

Droits de reproduction réservés. Sauf indication contraire, aucune partie de cette publication ne peut être reproduite ni utilisée sous quelque forme que ce soit et par aucun procédé, électronique ou mécanique, y compris la photocopie et les microfilms, sans l'accord écrit de l'IEC ou du Comité national de l'IEC du pays du demandeur. Si vous avez des questions sur le copyright de l'IEC ou si vous désirez obtenir des droits supplémentaires sur cette publication, utilisez les coordonnées ci-après ou contactez le Comité national de l'IEC de votre pays de résidence.

IEC Central Office
3, rue de Varembe
CH-1211 Geneva 20
Switzerland

Tel.: +41 22 919 02 11
info@iec.ch
www.iec.ch

About the IEC

The International Electrotechnical Commission (IEC) is the leading global organization that prepares and publishes International Standards for all electrical, electronic and related technologies.

About IEC publications

The technical content of IEC publications is kept under constant review by the IEC. Please make sure that you have the latest edition, a corrigendum or an amendment might have been published.

IEC publications search - webstore.iec.ch/advsearchform

The advanced search enables to find IEC publications by a variety of criteria (reference number, text, technical committee,...). It also gives information on projects, replaced and withdrawn publications.

IEC Just Published - webstore.iec.ch/justpublished

Stay up to date on all new IEC publications. Just Published details all new publications released. Available online and once a month by email.

IEC Customer Service Centre - webstore.iec.ch/csc

If you wish to give us your feedback on this publication or need further assistance, please contact the Customer Service Centre: sales@iec.ch.

Electropedia - www.electropedia.org

The world's leading online dictionary on electrotechnology, containing more than 22 000 terminological entries in English and French, with equivalent terms in 16 additional languages. Also known as the International Electrotechnical Vocabulary (IEV) online.

IEC Glossary - std.iec.ch/glossary

67 000 electrotechnical terminology entries in English and French extracted from the Terms and Definitions clause of IEC publications issued since 2002. Some entries have been collected from earlier publications of IEC TC 37, 77, 86 and CISPR.

A propos de l'IEC

La Commission Electrotechnique Internationale (IEC) est la première organisation mondiale qui élabore et publie des Normes internationales pour tout ce qui a trait à l'électricité, à l'électronique et aux technologies apparentées.

A propos des publications IEC

Le contenu technique des publications IEC est constamment revu. Veuillez vous assurer que vous possédez l'édition la plus récente, un corrigendum ou amendement peut avoir été publié.

Recherche de publications IEC -

webstore.iec.ch/advsearchform

La recherche avancée permet de trouver des publications IEC en utilisant différents critères (numéro de référence, texte, comité d'études,...). Elle donne aussi des informations sur les projets et les publications remplacées ou retirées.

IEC Just Published - webstore.iec.ch/justpublished

Restez informé sur les nouvelles publications IEC. Just Published détaille les nouvelles publications parues. Disponible en ligne et une fois par mois par email.

Service Clients - webstore.iec.ch/csc

Si vous désirez nous donner des commentaires sur cette publication ou si vous avez des questions contactez-nous: sales@iec.ch.

Electropedia - www.electropedia.org

Le premier dictionnaire d'électrotechnologie en ligne au monde, avec plus de 22 000 articles terminologiques en anglais et en français, ainsi que les termes équivalents dans 16 langues additionnelles. Egalement appelé Vocabulaire Electrotechnique International (IEV) en ligne.

Glossaire IEC - std.iec.ch/glossary

67 000 entrées terminologiques électrotechniques, en anglais et en français, extraites des articles Termes et Définitions des publications IEC parues depuis 2002. Plus certaines entrées antérieures extraites des publications des CE 37, 77, 86 et CISPR de l'IEC.

INTERNATIONAL STANDARD

NORME INTERNATIONALE

Connectors for electrical and electronic equipment – Product requirements – Part 3-123: Rectangular connectors – Detail specification for hybrid connectors for industrial environments, for power supply and fibre optic data transmission, with push-pull locking

Connecteurs pour équipements électriques et électroniques – Exigences de produit – Partie 3-123: Connecteurs rectangulaires – Spécification particulière relative aux connecteurs hybrides dans des environnements industriels pour l'alimentation et la transmission de données fibronique, avec verrouillage de type pousser-tirer

INTERNATIONAL
ELECTROTECHNICAL
COMMISSION

COMMISSION
ELECTROTECHNIQUE
INTERNATIONALE

ICS 31.220.10

ISBN 978-2-8322-7351-7

**Warning! Make sure that you obtained this publication from an authorized distributor.
Attention! Veuillez vous assurer que vous avez obtenu cette publication via un distributeur agréé.**

CONTENTS

FOREWORD.....	5
INTRODUCTION.....	7
1 Scope.....	8
2 Normative references	8
3 Terms, definitions, and abbreviated terms	12
3.1 Terms and definitions.....	12
3.2 Abbreviated terms.....	13
4 Technical information	13
4.1 Systems of levels.....	13
4.1.1 Performance levels	13
4.1.2 Compatibility levels, according to IEC 61076-1:2006.....	13
4.2 Classification into climatic categories.....	13
4.3 Clearance and creepage distances	14
4.4 Current-carrying capacity	14
4.5 Marking.....	14
5 Dimensional information	14
5.1 Common features.....	14
5.2 Reference system.....	14
5.3 Engagement (mating) information	14
5.3.1 Engaging (mating) direction	14
5.3.2 Contact levels and sequencing	15
5.3.3 Perpendicular to the engaging (mating) direction	15
5.3.4 Inclination.....	15
5.4 Fixed connectors	15
5.4.1 Fixed connectors – A-coding.....	15
5.4.2 Fixed connectors – B-coding.....	18
5.5 Free connectors.....	19
5.5.1 Free connectors – A – coding	19
5.5.2 Free connectors – B-coding	21
5.6 Accessories	22
5.7 Mounting information for connectors	22
5.8 Gauges.....	22
5.8.1 Sizing gauges and retention force gauges	22
5.8.2 Mechanical function, engaging/separating/insertion/withdrawal force gauges	23
5.8.3 Probes.....	23
5.8.4 Contact resistance gauge	23
5.8.5 Test panel (for voltage proof test).....	23
5.8.6 Test panel (for EMC/crosstalk, etc.).....	23
6 Characteristics	23
6.1 General.....	23
6.2 Pin assignment and other definitions.....	24
6.3 Classification into climatic categories.....	24
6.4 Electrical characteristics	24
6.4.1 Creepage and clearance distances	24
6.4.2 Voltage proof.....	24

6.4.3	Current-carrying capacity.....	24
6.4.4	Contact and shield resistance.....	25
6.4.5	Insulation resistance.....	25
6.4.6	Impedance.....	25
6.4.7	Transmission characteristics.....	25
6.5	Mechanical characteristics.....	25
6.5.1	Mechanical operation.....	25
6.5.2	Effectiveness of connector coupling devices.....	26
6.5.3	Engaging and separating forces (or insertion and withdrawal forces).....	26
6.5.4	Contact retention in insert.....	26
6.5.5	Polarizing and coding method.....	26
6.6	Other characteristics.....	26
6.6.1	Vibration (method half-sine).....	26
6.6.2	Shock (method half-sine).....	27
6.6.3	Degree of protection provided by enclosures (IP-code).....	28
6.6.4	Screen and shielding properties.....	28
6.6.5	Static load test.....	28
6.7	Environmental aspects.....	28
6.7.1	Marking of insulation material (plastics).....	28
6.7.2	Design/use of material.....	28
7	Test schedule.....	28
7.1	General.....	28
7.1.1	Overview.....	28
7.1.2	Climatic category.....	28
7.1.3	Creepage and clearance distances.....	29
7.1.4	Arrangement for contact resistance measurement.....	29
7.1.5	Arrangement for dynamic stress tests.....	30
7.1.6	Arrangement for testing static load, axial.....	30
7.1.7	Wiring of specimens.....	30
7.2	Test schedules.....	31
7.2.1	Basic (minimum) test schedule, see Table 12.....	31
7.2.2	Full test schedule.....	31
7.3	Test procedures and measuring methods.....	43
7.4	Pre-conditioning.....	43
7.5	Wiring and mounting of specimens.....	43
7.5.1	Wiring.....	43
7.5.2	Mounting.....	44
	Figure 1 – Section showing mating direction.....	14
	Figure 2 – Fixed connector with female contacts – A-coding.....	16
	Figure 3 – Fixed connector with female contacts – B-coding.....	18
	Figure 4 – Free connector with male contacts – A-coding.....	19
	Figure 5 – Free connector with male contacts – B-coding.....	22
	Figure 6 – Gauge dimensions.....	23
	Figure 7 – Vibration and shock test arrangement.....	27
	Figure 8 – Contact resistance arrangement.....	30

Table 1 – Climatic category.....	13
Table 2 – Dimensions of fixed connector – A-coding	17
Table 3 – Dimensions of fixed connector – B-coding	18
Table 4 – Dimensions of free connector – A-coding	20
Table 5 – Dimensions of free connector – B-coding	22
Table 6 – Gauge dimensions.....	23
Table 7 – Ratings of connectors.....	24
Table 8 – Current-carrying capacity	25
Table 9 – Number of mechanical operations	26
Table 10 – Total insertion force.....	26
Table 11 – Rated voltage – Rated impulse voltage – Pollution degree	29
Table 12 – Basic tests	31
Table 13 – Number of test specimens and contacts	32
Table 14 – Test group P	32
Table 15 – Test group AP	33
Table 16 – Test group BP	35
Table 17 – Test group CP	36
Table 18 – Test group DP	37
Table 19 – Test group EP	38
Table 20 – Test group FP	39
Table 21 – Test group GP	40
Table 22 – Test group JP	41
Table 23 – Test group KP	41

INTERNATIONAL ELECTROTECHNICAL COMMISSION

**CONNECTORS FOR ELECTRICAL AND ELECTRONIC EQUIPMENT –
PRODUCT REQUIREMENTS –**
**Part 3-123: Rectangular connectors – Detail specification for hybrid
connectors for industrial environments, for power supply and fibre optic
data transmission, with push-pull locking**

FOREWORD

- 1) The International Electrotechnical Commission (IEC) is a worldwide organization for standardization comprising all national electrotechnical committees (IEC National Committees). The object of IEC is to promote international co-operation on all questions concerning standardization in the electrical and electronic fields. To this end and in addition to other activities, IEC publishes International Standards, Technical Specifications, Technical Reports, Publicly Available Specifications (PAS) and Guides (hereafter referred to as "IEC Publication(s)"). Their preparation is entrusted to technical committees; any IEC National Committee interested in the subject dealt with may participate in this preparatory work. International, governmental and non-governmental organizations liaising with the IEC also participate in this preparation. IEC collaborates closely with the International Organization for Standardization (ISO) in accordance with conditions determined by agreement between the two organizations.
- 2) The formal decisions or agreements of IEC on technical matters express, as nearly as possible, an international consensus of opinion on the relevant subjects since each technical committee has representation from all interested IEC National Committees.
- 3) IEC Publications have the form of recommendations for international use and are accepted by IEC National Committees in that sense. While all reasonable efforts are made to ensure that the technical content of IEC Publications is accurate, IEC cannot be held responsible for the way in which they are used or for any misinterpretation by any end user.
- 4) In order to promote international uniformity, IEC National Committees undertake to apply IEC Publications transparently to the maximum extent possible in their national and regional publications. Any divergence between any IEC Publication and the corresponding national or regional publication shall be clearly indicated in the latter.
- 5) IEC itself does not provide any attestation of conformity. Independent certification bodies provide conformity assessment services and, in some areas, access to IEC marks of conformity. IEC is not responsible for any services carried out by independent certification bodies.
- 6) All users should ensure that they have the latest edition of this publication.
- 7) No liability shall attach to IEC or its directors, employees, servants or agents including individual experts and members of its technical committees and IEC National Committees for any personal injury, property damage or other damage of any nature whatsoever, whether direct or indirect, or for costs (including legal fees) and expenses arising out of the publication, use of, or reliance upon, this IEC Publication or any other IEC Publications.
- 8) Attention is drawn to the Normative references cited in this publication. Use of the referenced publications is indispensable for the correct application of this publication.
- 9) Attention is drawn to the possibility that some of the elements of this IEC Publication may be the subject of patent rights. IEC shall not be held responsible for identifying any or all such patent rights.

International Standard IEC 61076-3-123 has been prepared by subcommittee 48B: Electrical connectors, of IEC technical committee 48: Electrical connectors and mechanical structures for electrical and electronic equipment.

The text of this standard is based on the following documents:

FDIS	Report on voting
48B/2742/FDIS	48B/2753/RVD

Full information on the voting for the approval of this International Standard can be found in the report on voting indicated in the above table.

This document has been drafted in accordance with the ISO/IEC Directives, Part 2.

A list of all parts in the IEC 61076 series, published under the general title *Connectors for electrical and electronic equipment – Product requirements*, can be found on the IEC website.

Future standards in this series will carry the new general title as cited above. Titles of existing standards in this series will be updated at the time of the next edition.

The committee has decided that the contents of this document will remain unchanged until the stability date indicated on the IEC website under "<http://webstore.iec.ch>" in the data related to the specific document. At this date, the document will be

- reconfirmed,
- withdrawn,
- replaced by a revised edition, or
- amended.

INTRODUCTION

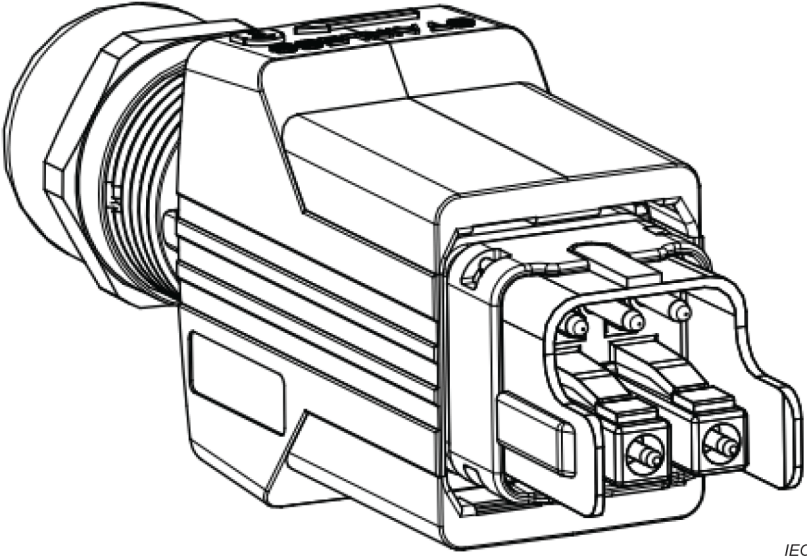
<p>IEC SC 48B – Electrical connectors Specification available from: IEC General secretariat or from the addresses shown on the inside cover.</p>	<p>IEC 61076-3-123 Ed.1</p>
<p>DETAIL SPECIFICATION in accordance with IEC 61076-1</p>	
	<p>Rectangular connectors Detail specification for hybrid connectors for industrial environments, for power supply and fibre optic data transmission, with push-pull locking Male and female connectors Male and female contacts Optical ferrules and adaptors Rewirable – Non-rewirable</p>
	<p>Free cable connectors Straight and right angle connectors Fixed connectors Flange mounting Single hole mounting</p>

CONNECTORS FOR ELECTRICAL AND ELECTRONIC EQUIPMENT – PRODUCT REQUIREMENTS –

Part 3-123: Rectangular connectors – Detail specification for hybrid connectors for industrial environments, for power supply and fibre optic data transmission, with push-pull locking

1 Scope

This part of IEC 61076 covers hybrid rectangular connectors with a 3 poles 16 A electric portion for power supply and a duplex fibre optic connector type LC portion for data transmission. These connectors consist of fixed and free connectors, either rewirable or non-rewirable (for both portions) and use the rectangular push-pull housing described in IEC 61076-3-117 with IP65/IP67 degree of protection, for harsh applications. The mating dimensions of such housings allow fulfilling the performance class Category I according to IEC 61753-1-3 in regards to the fibre optic portion of the connector with the exception of the operating temperature range which is $-25\text{ °C}/+70\text{ °C}$.

The electric portion may have different rated insulation voltages. Male connectors have 3 electric round contacts $\text{Ø}1,6\text{ mm}$, with 16 A rated current.

NOTE Only the phase/neutral contacts are loaded upon current-carrying capacity test of 4.4 and 6.4.3 and electrical load and temperature test in 7.2.2.6 (DP2) and 7.2.2.12 (KP5)

The fibre optic portion provides data transmission by using the common mating configurations for all variants of the type LC duplex fibre optic connectors as defined in IEC 61754-20, for dedicated fibre types and fibre termination technology covered therein.

The different codings provided by this document prevent the mating of accordingly coded male or female connectors to any other similarly sized interfaces covered by other standards and the cross-mating between the different codings provided by this document.

2 Normative references

The following documents are referred to in the text in such a way that some or all of their content constitutes requirements of this document. For dated references, only the edition cited applies. For undated references, the latest edition of the referenced document (including any amendments) applies.

IEC 60050-581:2008, *International Electrotechnical Vocabulary – Chapter 581: Electro-mechanical components for electronic equipment*

IEC 60068-1, *Environmental testing – Part 1: General and guidance*

IEC 60068-2-30, *Environmental testing – Part 2-30: Tests – Test Db: Damp heat, cyclic (12 h + 12 h cycle)*

IEC 60352-1:1997, *Solderless connections – Part 1: Wrapped connections – General requirements, test methods and practical guidance*

IEC 60352-2:2006, *Solderless connections – Part 2: Crimped connections – General requirements, test methods and practical guidance*