

AS 61869.9:2021



Instrument transformers

**Part 9: Digital interface for instrument transformers
(IEC 61869-9:2016 (ED 1.0) MOD)**



AS 61869.9:2021

This Australian Standard® was prepared by EL-013, Measurement And Protection Transformers. It was approved on behalf of the Council of Standards Australia on 11 February 2021.

This Standard was published on 26 February 2021.

The following are represented on Committee EL-013:

- Australian Industry Group
- Energy Networks Australia
- Engineers Australia
- National Measurement Institute
- University of South Australia

This Standard was issued in draft form for comment as AS 61869.9.

Keeping Standards up-to-date

Ensure you have the latest versions of our publications and keep up-to-date about Amendments, Rulings, Withdrawals, and new projects by visiting:

www.standards.org.au

ISBN 978 1 76113 220 9

Instrument transformers

Part 9: Digital interface for instrument transformers (IEC 61869-9:2016 (ED 1.0) MOD)

First published as AS 61869.9:2021.



© IEC 2021 — All rights reserved
© Standards Australia Limited 2021

All rights are reserved. No part of this work may be reproduced or copied in any form or by any means, electronic or mechanical, including photocopying, without the written permission of either the IEC or the publisher, unless otherwise permitted under the Copyright Act 1968 (Cth). If you have any questions about IEC copyright or have an enquiry about obtaining additional rights to this publication, please see the contact details on the back cover or the contact us page of the website for further information.

Preface

This Standard was prepared by the Standards Australia Committee EL-013, Measurement and Protection Transformers.

The objective of this document is to define requirements for digital communications of instrument transformer measurements.

This document includes additional improvements, including the IEC 61588 network-based time synchronization. This document applies to instrument transformers with digital output.

This document is an adoption with national modifications, and has been reproduced from, IEC 61869-9:2016, *Instrument transformers — Part 9: Digital interface for instrument transformers*.

The modifications are additional requirements and are set out in [Appendices ZZ](#), which has been added at the end of the source text.

[Appendix ZZ](#) lists the variation to IEC 61869-9:2016 for the application of this document in Australia.

As this document has been reproduced from an International Standard, the following applies:

- (a) In the source text “this part of 61869” should read “this document”.
- (b) A full point substitutes for a comma when referring to a decimal marker.

Australian or Australian/New Zealand Standards that are identical adoptions of international normative references may be used interchangeably. Refer to the online catalogue for information on specific Standards.

The terms “normative” and “informative” are used in Standards to define the application of the appendices or annexes to which they apply. A “normative” appendix or annex is an integral part of a Standard, whereas an “informative” appendix or annex is only for information and guidance.

NOTES

CONTENTS

FOREWORD.....	4
INTRODUCTION.....	7
1 Scope	12
2 Normative references	12
3 Terms and definitions	13
3.5 Terms and definitions related to other ratings.....	13
3.7 Index of abbreviations.....	13
4 Normal and special service conditions.....	14
5 Ratings	14
5.6 Rated accuracy class.....	14
5.901 Performance requirements	15
6 Design and construction	16
6.901 Technological boundaries.....	16
6.901.1 Interface point	16
6.901.2 Digital output interface.....	16
6.901.3 Human-machine interface	16
6.902 Electrical requirements.....	17
6.902.1 Frequency response requirements	17
6.902.2 Maximum processing delay time requirement	17
6.903 Specification of the communications profile	19
6.903.1 General.....	19
6.903.2 Variants	19
6.903.3 Digital output sample rates	20
6.903.4 Logical devices.....	21
6.903.5 Logical nodes LPHD	21
6.903.6 Logical nodes LLN0	21
6.903.7 Logical nodes TCTR	21
6.903.8 Logical nodes TVTR	24
6.903.9 Quality	25
6.903.10 Dataset(s)	26
6.903.11 Multicast sampled value control block(s)	27
6.903.12 Configuration of the merging unit	27
6.903.13 Rated conformance classes	28
6.904 Synchronization	34
6.904.1 General.....	34
6.904.2 Precision time protocol synchronization.....	34
6.904.3 1PPS synchronization.....	35
6.904.4 Sample value message SmpSynch attribute	35
6.904.5 Holdover mode	36
6.904.6 Free-running mode	37
6.904.7 Time adjustments	37
7 Tests.....	38
7.2 Type tests.....	38
7.2.6 Test for accuracy.....	38
7.2.901 Digital output conformance tests	38
7.2.902 Maximum processing delay time test.....	38

7.2.903	Loss of synchronization tests	39
7.2.904	1PPS test	39
Annex 9A (informative)	Dynamic range considerations	40
Annex 9B (informative)	Time synchronization and management example	43
Annex 9C (informative)	Example merging unit ICD file	45
Annex 9D (informative)	Test circuits for accuracy measurement	56
Annex 9E (informative)	Electronic nameplate	59
Bibliography	60
Figure 901	– General block diagram of an electronic LPIT with digital output	8
Figure 902	– General illustration of the objects within a merging unit (example)	9
Figure 903	– Electronic LPIT with digital output (concept example)	10
Figure 904	– Standalone merging unit	11
Figure 905	– Duplex LC connector	16
Figure 906	– Maximum processing delay time	17
Figure 907	– Output message timestamp point	19
Figure 908	– TCTR naming example	23
Figure 909	– 1PPS signal waveform at the merging unit clock input	35
Figure 910	– Time adjustment example (6 ASDU example)	37
Figure 9A.1	– Nomogram for current	41
Figure 9A.2	– Nomogram for voltage	42
Figure 9B.1	– Sampled value signal processing example showing 2ASDUs per message (F4800S2I4U4 example)	43
Figure 9D.1	– Example test circuit	56
Figure 9D.2	– Example test circuit	58
Table 901	– Maximum processing delay time limits	18
Table 902	– Standard sample rates	20
Table 903	– Extensions to the LPHD class	21
Table 904	– AmpSv object attribute values	23
Table 905	– Extensions to the TCTR class	24
Table 906	– VoISv object attribute values	25
Table 907	– Extensions to the TVTR class	25
Table 908	– Configuration parameters of the merging unit	28
Table 909	– Basic conformance statement	29
Table 910	– ACSI models conformance statement	29
Table 911	– ACSI service conformance statement	31
Table 912	– PICS for A-Profile support	33
Table 913	– PICS for T-Profile support	34

INTERNATIONAL ELECTROTECHNICAL COMMISSION

INSTRUMENT TRANSFORMERS –

Part 9: Digital interface for instrument transformers

FOREWORD

- 1) The International Electrotechnical Commission (IEC) is a worldwide organization for standardization comprising all national electrotechnical committees (IEC National Committees). The object of IEC is to promote international co-operation on all questions concerning standardization in the electrical and electronic fields. To this end and in addition to other activities, IEC publishes International Standards, Technical Specifications, Technical Reports, Publicly Available Specifications (PAS) and Guides (hereafter referred to as “IEC Publication(s)”). Their preparation is entrusted to technical committees; any IEC National Committee interested in the subject dealt with may participate in this preparatory work. International, governmental and non-governmental organizations liaising with the IEC also participate in this preparation. IEC collaborates closely with the International Organization for Standardization (ISO) in accordance with conditions determined by agreement between the two organizations.
- 2) The formal decisions or agreements of IEC on technical matters express, as nearly as possible, an international consensus of opinion on the relevant subjects since each technical committee has representation from all interested IEC National Committees.
- 3) IEC Publications have the form of recommendations for international use and are accepted by IEC National Committees in that sense. While all reasonable efforts are made to ensure that the technical content of IEC Publications is accurate, IEC cannot be held responsible for the way in which they are used or for any misinterpretation by any end user.
- 4) In order to promote international uniformity, IEC National Committees undertake to apply IEC Publications transparently to the maximum extent possible in their national and regional publications. Any divergence between any IEC Publication and the corresponding national or regional publication shall be clearly indicated in the latter.
- 5) IEC itself does not provide any attestation of conformity. Independent certification bodies provide conformity assessment services and, in some areas, access to IEC marks of conformity. IEC is not responsible for any services carried out by independent certification bodies.
- 6) All users should ensure that they have the latest edition of this publication.
- 7) No liability shall attach to IEC or its directors, employees, servants or agents including individual experts and members of its technical committees and IEC National Committees for any personal injury, property damage or other damage of any nature whatsoever, whether direct or indirect, or for costs (including legal fees) and expenses arising out of the publication, use of, or reliance upon, this IEC Publication or any other IEC Publications.
- 8) Attention is drawn to the Normative references cited in this publication. Use of the referenced publications is indispensable for the correct application of this publication.
- 9) Attention is drawn to the possibility that some of the elements of this IEC Publication may be the subject of patent rights. IEC shall not be held responsible for identifying any or all such patent rights.

International Standard IEC 61869-9 has been prepared by IEC technical committee 38: Instrument transformers.

This first edition replaces the corresponding specific requirements previously contained in IEC 60044-8, published in 2002.

The text of this standard is based on the following documents:

FDIS	Report on voting
38/502/FDIS	38/508/RVD

Full information on the voting for the approval of this standard can be found in the report on voting indicated in the above table.

This publication has been drafted in accordance with the ISO/IEC Directives, Part 2.

A list of all parts in the IEC 61869 series, published under the general title *Instrument transformers*, can be found on the IEC website.

This publication contains an attached file in the form of a .xml file. This file is intended to be used as a complement and does not form an integral part of the publication.

This International Standard contains specific requirements for electronic low power instrument transformers (LPIT) having a digital output.

This Part 9 is to be read in conjunction with, and is based on, IEC 61869-1:2007, *General Requirements* and IEC 61869-6:2016. However, the reader is encouraged to use its most recent edition.

This Part 9 follows the structure of IEC 61869-6 and IEC 61869-1 and supplements or modifies their corresponding clauses/subclauses.

When a particular clause/subclause of Part 6 is not mentioned in this Part 9, that clause/subclause applies. When this standard states “addition”, “modification” or “replacement”, the relevant text in Part 6 is to be adapted accordingly.

When a particular clause/subclause of Part 1 is not mentioned in Part 6, that clause/subclause applies. When part 6 states “addition”, “modification” or “replacement”, the relevant text in Part 1 is to be adapted accordingly.

For additional clauses, subclauses, figures, tables, annexes or note, the following numbering system is used:

- clauses, subclauses, tables, figures and notes that are numbered starting from 901 are additional to those in Part 1;
- additional annexes are lettered 9A, 9B, etc.

An overview of the planned set of standards at the date of publication of this document is given below. The updated list of standards issued by IEC TC38 is available at the website: www.iec.ch

PRODUCT FAMILY STANDARDS		PRODUCT STANDARD IEC	PRODUCTS	OLD STANDARD IEC
61869-1 GENERAL REQUIREMENTS FOR INSTRUMENT TRANSFORMERS		61869-2	ADDITIONAL REQUIREMENTS FOR CURRENT TRANSFORMERS	60044-1 60044-6
		61869-3	ADDITIONAL REQUIREMENTS FOR INDUCTIVE VOLTAGE TRANSFORMERS	60044-2
		61869-4	ADDITIONAL REQUIREMENTS FOR COMBINED TRANSFORMERS	60044-3
		61869-5	ADDITIONAL REQUIREMENTS FOR CAPACITOR VOLTAGE TRANSFORMERS	60044-5
		61869-6	ADDITIONAL GENERAL REQUIREMENTS FOR LOW POWER INSTRUMENT TRANSFORMERS	
		61869-7	ADDITIONAL REQUIREMENTS FOR ELECTRONIC VOLTAGE TRANSFORMERS	60044-7
		61869-8	ADDITIONAL REQUIREMENTS FOR ELECTRONIC CURRENT TRANSFORMERS	60044-8
		61869-9	DIGITAL INTERFACE FOR INSTRUMENT TRANSFORMERS	
		61869-10	ADDITIONAL REQUIREMENTS FOR LOW POWER PASSIVE CURRENT TRANSFORMERS	
		61869-11	ADDITIONAL REQUIREMENTS FOR LOW POWER VOLTAGE TRANSFORMERS	60044-7
		61869-12	ADDITIONAL REQUIREMENTS FOR COMBINED ELECTRONIC INSTRUMENT TRANSFORMERS AND COMBINED STAND ALONE INSTRUMENT TRANSFORMERS	
		61869-13	STAND ALONE MERGING UNIT	
		61869-14	ADDITIONAL REQUIREMENTS FOR DC CURRENT TRANSFORMERS	
		61869-15	ADDITIONAL REQUIREMENTS FOR DC VOLTAGE TRANSFORMERS FOR DC APPLICATIONS	

The committee has decided that the contents of this publication will remain unchanged until the stability date indicated on the IEC web site under "<http://webstore.iec.ch>" in the data related to the specific publication. At this date, the publication will be

- reconfirmed,
- withdrawn,
- replaced by a revised edition, or
- amended.

A bilingual version of this publication may be issued at a later date.

IMPORTANT – The 'colour inside' logo on the cover page of this publication indicates that it contains colours which are considered to be useful for the correct understanding of its contents. Users should therefore print this document using a colour printer.

INTRODUCTION

General

This standard is a product family standard for instrument transformers. It provides an application of the standard series IEC 61850, which details layered substation communication architecture in the world of instrument transformers.

By providing tutorial material such as examples and explanations, it also provides access for instrument transformer, protective relay and meter experts to concepts and methods applied in the IEC 61850 series.

Compared to instrument transformers, digital communication technology is subject to on-going changes which are expected to continue in the future. Significant experience with electronics integrated directly into instrument transformers has yet to be gathered on a broader basis, as this type of equipment is not widely spread in the industry and a change of paradigm has not yet occurred.

Position of this standard in relation to the IEC 61850 series

The IEC 61850 series is a standard intended to be used for communication networks and systems for power utility automation. The most important parts of this series define:

- a) information models for the substation automation system;
- b) these information models include both the models of the instrument transformers and other process equipment (like circuit-breakers and disconnectors), and the models of the substation automation system (like protection relays and meters). The models are defined in IEC 61850-7-3 and IEC 61850-7-4;
- c) the communication between intelligent electronic devices (IEDs) of the substation automation system. The abstract models are defined in IEC 61850-7-2 and the mappings on communication stacks are defined in IEC 61850-8-1 and IEC 61850-9-2;
- d) a configuration language used to describe the configuration aspects of the substation automation system is described in IEC 61850-6;
- e) conformance testing of the communication interfaces of the IEDs of the power utility automation system including their data models. The conformance testing is defined in IEC 61850-10.

Typically, in a traditional system, IEDs like bay level controllers or protection relays interface directly through analogue signals to instrument transformers. In that case, the data models of the instrument transformers are implemented in these bay level devices. However, this is not the only realization. In the case where electronics are integrated directly into electronic LPIT, the above-mentioned data models should be implemented within the instrument transformer and the instrument transformer needs to support a communication interface. The part of an electronic LPIT that does this is known as the merging unit.

IEC 61850, being a system oriented standard series, leaves many options open in order to support present and future requirements of all sizes of substations at all voltage levels.

To reduce the engineering amount required to achieve interoperability for the digital interface between instrument transformers and equipment that uses the digital signal (like protective relays, meters or bay level controllers), this standard specifies additional constraints on implementing a digital communication interface.

The IEC 61869-9 standard:

- replaces the IEC 60044-8 digital solution;

- provides a product standard for instrument transformers with a digital interface according to the IEC 61850 series; similar to what IEC 62271-3 offers for switchgear;
- includes backward compatibility for the UCA International Users Group *Implementation Guideline for Digital Interface to Instrument Transformers Using IEC 61850-9-2*;
- uses IEC 61588 based time synchronization in accordance with IEC/IEEE 61850-9-3, with an option for 1PPS (pulse per second).

Overview of the digital interface for instrument transformers

An illustrative general block diagram of an instrument transformer with digital output is shown in Figure 901. It shows multiple current and/or voltage information coming from the secondary converters (SC in Figure 901) and fed into a common block labelled “merging unit”. The merging unit performs all the data processing (sampling, analogue to digital conversion, scaling, message formatting, etc.) necessary to produce a time-coherent output data stream according to this standard. For the purposes of this standard a merging unit is a physical unit (hardware subsystem) used to assemble and transmit digital output data frames.

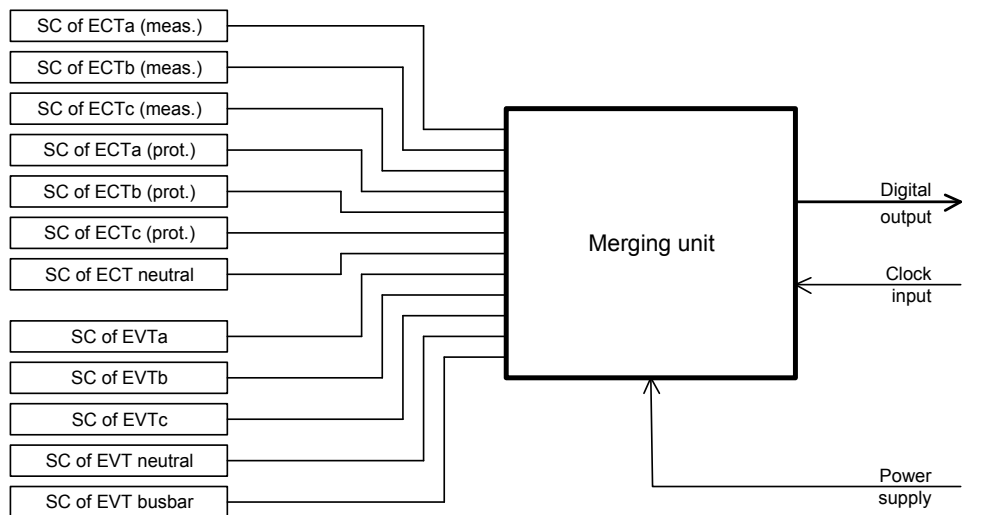

IEC

Figure 901 – General block diagram of an electronic LPIT with digital output

A merging unit is modelled as one or more logical devices that contain multiple logical nodes as illustrated in Figure 902.

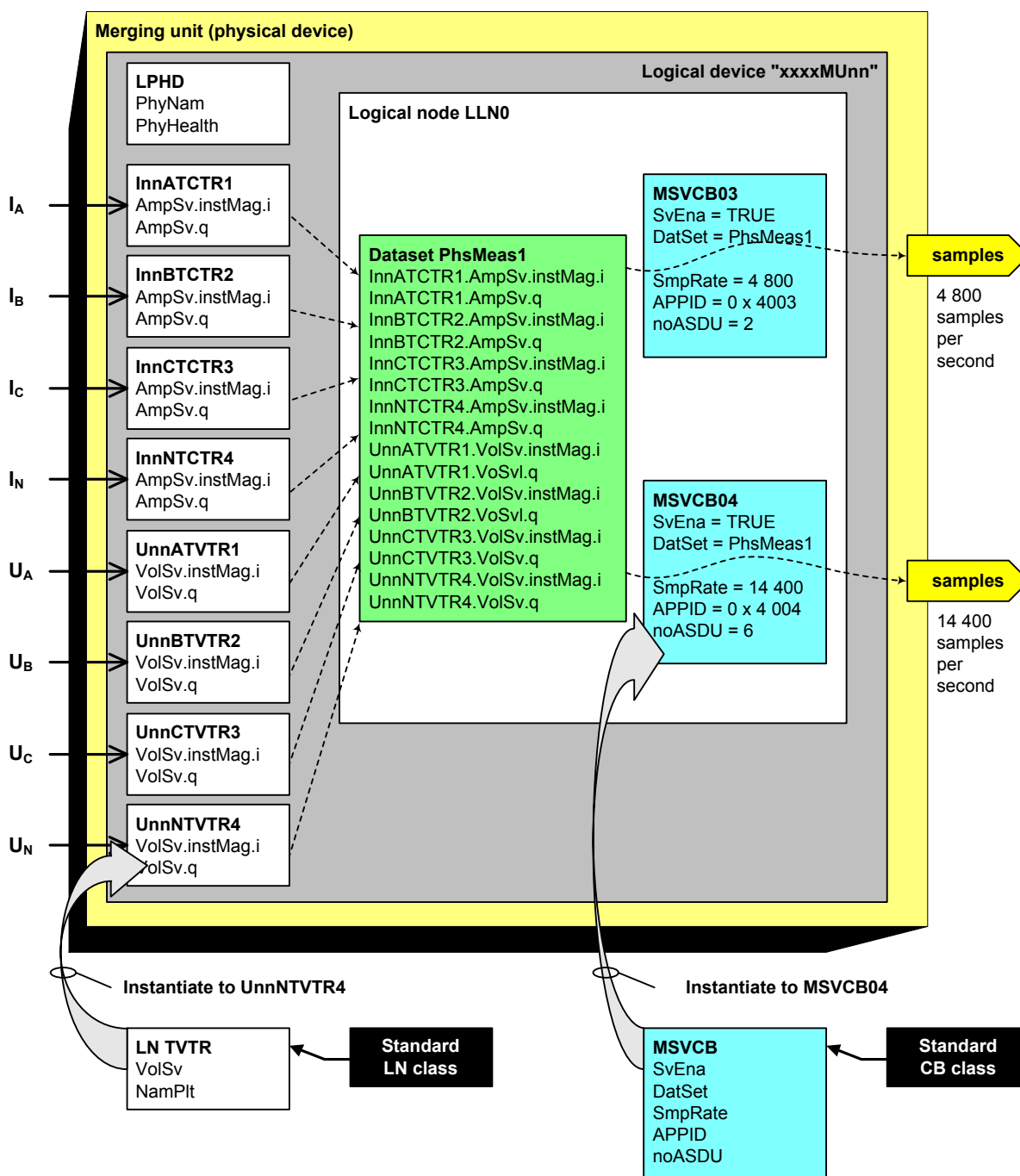

IEC

Figure 902 – General illustration of the objects within a merging unit (example)

Current and voltage measurements in the example merging unit in Figure 902 are modelled per IEC 61850-7-1 by using the following logical nodes:

- Class **TCTR** per IEC 61850-7-4, instantiated individually for each of the three current transformer phases, and for the neutral current measurement.
- Class **TVTR** per IEC 61850-7-4, instantiated individually for each of the three voltage transformer phases, and for the neutral voltage measurement.
- Logical node zero **LLN0** containing instances of the sampled value control blocks (MSVCB03 and MSVCB04 in this example) controlling simultaneous publishing of IEC 61850-9-2 data streams (in this example one with 4 800 samples per second and 2 samples per frame yielding a frame rate of 2 400 per second, the other with 14 400 samples per second and 6 samples per frame also yielding a frame rate of

2 400 per second), and a dataset that controls the content of the sampled value digital output messages.

Applicable sample rates, time synchronization, control blocks and dataset are defined in this standard.

Physical realization of the above concepts may vary with the applied technology determining which parts are necessary for the realization of an actual instrument transformer. One such realization showing an electronic LPIT with built-in digital data output is shown in Figure 903 and further described in the relevant product specific standards in the IEC 61869 series (Part 7, Part 8, Part 12, Part 14, Part 15).

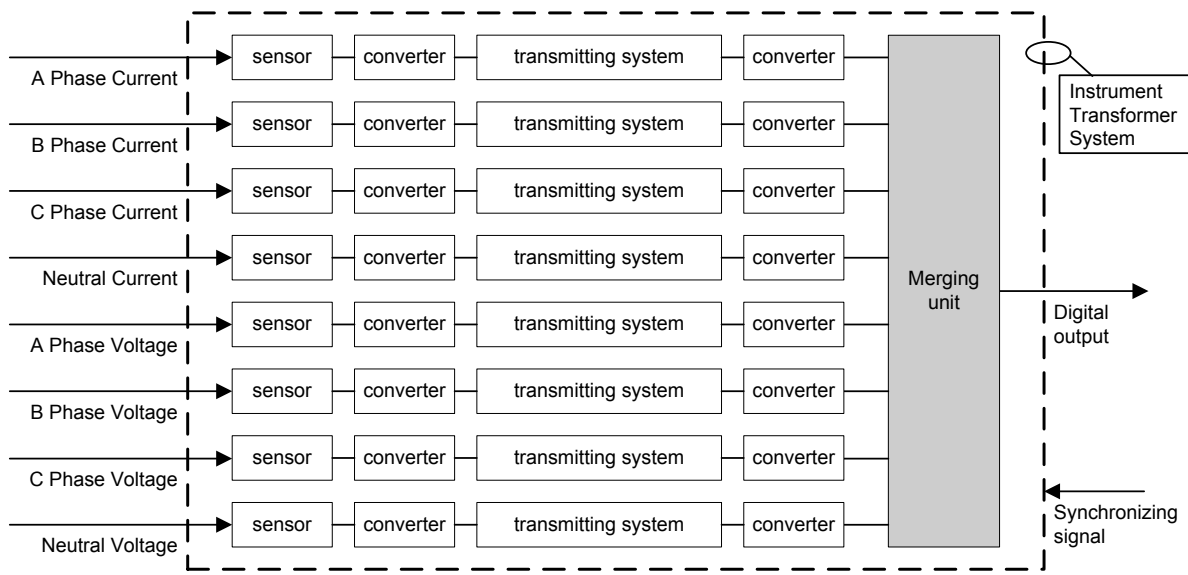

IEC

Figure 903 – Electronic LPIT with digital output (concept example)

It is not absolutely necessary that all parts shown in Figure 903 be included. For clarity, power supplies are not shown here. An instrument transformer may be implemented in a single physical unit or in multiple physical units. For example, there may be a separate physical unit for each phase containing the primary voltage and/or current sensors, primary converters and primary insulation, with all secondary converters and the merging unit in a separate physical unit located in the control house. The number of primary inputs and their type (voltage or current) in a single instrument transformer may be other than shown here.

For comparison, an illustrative general block diagram of an installation using a stand-alone merging unit (SAMU) is shown in Figure 904. Unlike the merging unit in an instrument transformer, a SAMU is a separate product covered in IEC 61869-13. It accepts as inputs the outputs of instrument transformers, said outputs conforming to the specifications of one of the product standards in the IEC 61869 series. The number of inputs and their type (voltage or current) may be other than shown in Figure 904. Output produced by a SAMU and output produced by an electronic LPIT with built in merging unit should in principle be indistinguishable from each other (excluding the fact that SAMU output will typically have lower accuracy due to cascading the separately given instrument transformer and SAMU accuracy specifications).

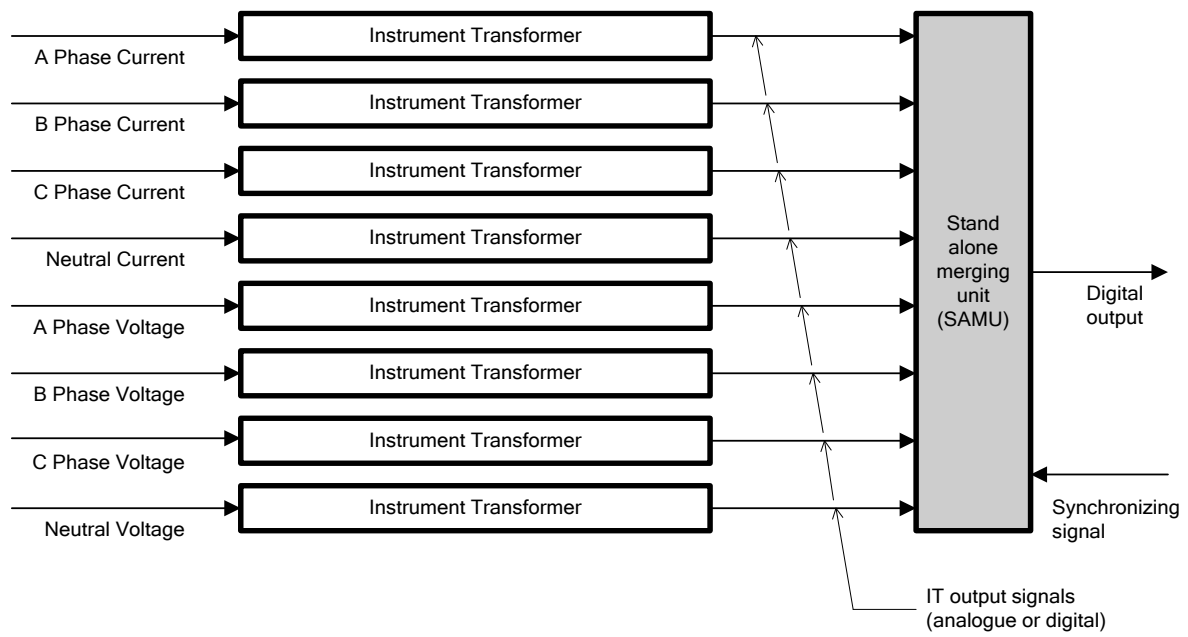

IEC

An example will be presented in IEC 61869-13¹, as soon as this standard will be available.

Figure 904 – Standalone merging unit

¹ Under consideration.

INSTRUMENT TRANSFORMERS –

Part 9: Digital interface for instrument transformers

1 Scope

This part of IEC 61869 is a product family standard applicable to instrument transformers with digital output. The product standard is composed of IEC 61869-1 and IEC 61869-6, in addition to this standard and the relevant product specific standards in the IEC 61869 series (Part 7, Part 8, Part 12, Part 13, Part 14, and Part 15).

This standard defines requirements for digital communications of instrument transformer measurements. It is based on the IEC 61850 series, UCA international users group document *Implementation guideline for digital interface to instrument transformers using IEC 61850-9-2*, and the relevant parts of IEC 60044-8 that are replaced by this standard. It includes additional improvements including the IEC 61588 network based time synchronization.

2 Normative references

The following documents, in whole or in part, are normatively referenced in this document and are indispensable for its application. For dated references, only the edition cited applies. For undated references, the latest edition of the referenced document (including any amendments) applies.

Clause 2 of IEC 61869-6:2016 is applicable with the following additions:

IEC 61588:2009, *Precision clock synchronization protocol for networked measurement and control systems*

IEC 61850-6:2009, *Communication networks and systems for power utility automation – Part 6: Configuration description language for communication in electrical substations related to IEDs*

IEC 61850-7-1:2011, *Communication networks and systems for power utility automation – Part 7-1: Basic communication structure – Principles and models*

IEC 61850-7-2:2010, *Communication networks and systems for power utility automation – Part 7-2: Basic information and communication structure – Abstract communication service interface (ACSI)*

IEC 61850-7-3:2010, *Communication networks and systems for power utility automation – Part 7-3: Basic communication structure – Common data classes*

IEC 61850-8-1:2011, *Communication networks and systems for power utility automation – Part 8-1: Specific communication service mapping (SCSM) – Mappings to MMS (ISO 9506-1 and ISO 9506-2) and to ISO/IEC 8802-3*

IEC 61850-9-2:2011, *Communication networks and systems for power utility automation – Part 9-2: Specific communication service mapping (SCSM) – Sampled values over ISO/IEC 8802-3*

IEC/IEEE 61850-9-3:2016, *Communication networks and systems for power utility automation – Part 9-3: Precision time protocol profile for power utility automation*